

# HSS<sup>®</sup> AIR HANDLER

BY B&D MFG., INC.



LET US BE YOUR HEATING AND COOLING HYDRONIC SOLUTION



**B&D**  
MFG, INC.<sup>®</sup>

[WWW.BDMFGINC.COM](http://WWW.BDMFGINC.COM)

1 TON 2 TON 3 TON 4 TON 5 TON

HSS<sup>®</sup> AIR HANDLER INSTALLATION MANUAL

# TABLE OF CONTENTS

General Instructions.....	3
Warranty Information.....	3
Terms of Limited Warranty Information.....	3
Safety Considerations.....	4
Installation Precautions.....	4
Air Distribution Duct Information.....	5
Electrical Wiring Information.....	5
Mounting the Air Handler.....	5
Pre Start –Up.....	6
Start-up & Maintenance .....	6
Preventative Maintenance.....	6
Air Handler Unit Information.....	7
Air Handler Unit Access.....	8
Heat Strip Installation Procedure.....	9
Emergency Heat Sequence of Operation.....	10
Electrical Data Information All Units.....	11
Air Handler Piping Diagram & Piping Connections.....	12
1 Ton, 2 Ton Wiring Schematic.....	13
3 Ton, 4 Ton, 5 Ton Wiring Schematic.....	14
1 Ton, 2 Ton Speed Lug Terminal Lug Assignment.....	15
3 Ton, 4 Ton, 5 Ton Speed Lug Terminal Lug Assignment.....	16
Wiring HSS® Air Handler to the HSS® Buffer Tank.....	17
1 Ton Cooling Data.....	18
1 Ton Heating Data.....	19
1 Ton Electric Heat Strip Data.....	19
2 Ton Cooling Data.....	20
2 Ton Heating Data.....	21
2 Ton Electric Heat Strip Data.....	21
3 Ton Cooling Data.....	22
3 Ton Heating Data.....	23
3 Ton Electric Heat Strip Data.....	23
4 Ton Cooling Data.....	24
4 Ton Heating Data.....	25
4 Ton Electric Heat Strip Data.....	25
5 Ton Cooling Data.....	26
5 Ton Heating Data.....	27
5 Ton Electric Heat Strip Data.....	27
Boiler Heating Data 1 & 2 Ton Unit.....	28
Boiler Heating Data 3 & 4 Ton Unit.....	29
Boiler Heating Data 5 Ton Unit.....	30
Notes.....	31
Company Contact Information.....	32



# HSS® AIR HANDLER

BY B&D MFG., INC.

## INSTALLATION INSTRUCTIONS

**NOTE:** *Read the entire instruction manual before starting the installation.*

### GENERAL

B&D Mfg., Inc. assumes no responsibility for equipment installed in violation of any code requirement. These instructions give information relative to the installation of the HSS® Air Handler units only. For other related equipment refer to the proper instructions.

Altering the product or replacing parts with non authorized factory parts voids all warranty or implied warranty and may result in adverse operational performance and/or a possible hazardous safety condition to service personnel and occupants. Company employees and/or contractors are not authorized to waive this warning.

Material in this shipment has been inspected at the factory and released to the transport agency in good condition. When received, a visual inspection of all HSS® Air Handler units should be made immediately. Any evidence of apparent damage should be noted on the delivery receipt and the material inspected in the presence of the carrier's representative. If damage is found, a claim should be filed against the carrier immediately.

B&D Mfg., Inc. reserves the right to discontinue, make changes to, and add improvements upon its products at any time without public notice or obligation. The descriptions and specifications contained in this manual were in effect at printing. Some illustrations and information in the installation guide may not be applicable to your unit.

### WARRANTY

B & D Mfg., Inc. warrants for a period of (36) months from the date of purchase that all HSS® Air Handler Models are free from defects in materials or workmanship.

You must contact the Warranty Department at B&D Mfg., Inc. for a Return Authorization Form. The alleged defective product must be returned to B&D Mfg., Inc. for inspection via prepaid freight. Defective parts will be repaired or replaced at the manufacturer's discretion. No allowance for labor or property damage is implied.

This warranty applies only to the HSS® Air Handler and does not include any other products or materials furnished by the installer. This warranty does not cover defects caused by adhere to local building codes and following good industry standards. The manufacturer does NOT WARRANT equipment subjected to abuse. Any abuse can void warranties.

### TERMS OF LIMITED WARRANTY

Limited Warranty is only applicable to products installed for use in ground source heat pump systems using clean potable water. Complete unit replacements are not covered, defective parts will be repaired and/or replaced at the Manufacturer's discretion. Limited Warranty shall not apply if serial number or data plates have been removed or altered. Warranty will be null and void. Limited Warranty shall not apply if products are not installed and maintained according to instructions in the product installation manual. Replacement and/or factory repaired parts are warranted only for the remainder of the original warranty period. B&D Mfg., Inc. does not warrant products that have been modified from original design. Any product returned with design deviations will null and void any and all warranties. B&D Mfg., Inc. is not responsible for any labor, shipping and transportation costs. In no event will liability exceed the purchase price of the product.

## SAFETY CONSIDERATIONS

Installing and servicing of air conditioning and heating equipment can be hazardous due to system pressures and electrical components. Only trained, qualified personnel should install, start-up and service this equipment. Untrained personnel can perform basic maintenance functions such as cleaning coils or cleaning and replacing filters. All other operations should be performed by trained service personnel.

When working on the equipment, observe precautions in the literature, tags, stickers and labels attached to the equipment and to any other safety precautions that apply.

When the HSS® Air Handler is operating, some components are operating at high speeds. Personal injury can result from touching these items with any object. All electrical and service access panels must be returned and secured in their proper place. Clear surrounding area of all tools, equipment and debris. Check the entire unit to ensure it's cleanliness.

Follow all safety codes. Wear safety glasses and work gloves.

## INSTALLATION PRECAUTIONS

Installation of the HSS® Air Handler should only be performed by a licensed contractor to ensure proper installation and the safety of the installer. The following are some precautions to be followed for typical installations.

- Always use proper tools and equipment.
- No wiring or other work should be attempted without first ensuring that the fan coil is completely disconnected from the power source and locked out. Always verify that a good ground connection exists prior to energizing any power sources.
- Always review the nameplate on each unit for proper voltage and control configurations. This information is determined from the components and wiring of the unit and may vary from unit to unit.
- Units must be installed level to ensure proper drainage and operation.
- Check unit prior to operation to ensure that the condensate water will drain toward the drain connection. An overflow drain or an overflow switch installed in the HSS® Air Handler may be required as a back up to a clogged primary drain.
- Be sure that the drain pan is free from foreign material prior to start up.
- Check filter media installation to ensure that it is installed correctly. Use the directional arrows or other information on the filter to determine the proper flow direction.
- Ensure that the air distribution system does not exceed the external static rating of the unit.



**WARNING:** *When the HSS® Air Handler unit is in operation, components are rotating at high speeds.*

**NOTE:** It is important at this point to consider noise and vibration. If this installation is in a noise sensitive area then placement of resilient isolators or other means of sound deadening may be necessary. These fan coil units are designed for quiet operation, however, all air conditioning equipment will transfer some amount of noise to the conditioned space. This should be taken into consideration when planning the location of the equipment as well.

## AIR DISTRIBUTION DUCTS

All duct work must be installed in accordance with National Fire Protection Association Codes 90A and 90B. Ducts should be adequately insulated to prevent condensation during the cooling cycle and to minimize heat loss during the heating cycle. The manufacturer will not be responsible for misapplied equipment. Flex duct should be attached at the exhaust duct flanges to reduce sound and vibration. Refer to page 5 for the location of the exhaust duct flanges.



**WARNING:** *The unit must not be operated under any circumstances without an air filter in place.*

## ELECTRICAL

All wiring must comply with local and national code requirements. Units are provided with wiring diagrams and name plate data to provide information required for necessary field wiring. Knockouts are provided on the cabinet for connection of power supply. The HSS® Air Handlers are provided with a Class 2 transformer or 24-volt control circuits.



**WARNING:** *Field installation must be wired in strict accordance with the wiring diagram that is supplied with the unit. Failure to do so could result in damage to components and will void all warranties.*



**WARNING:** *Only use electric heat strip components provided by B&D Mfg., Inc. The electric heat strip components were specially designed for the HSS® Air Handler. Any use of different components may not be a compatible fit and may cause harm to the unit and will void all warranty.*

## MOUNTING

It is important to ensure that the HSS® Air Handler is securely mounted and the structure is sufficient to support the weight of the equipment. All anchors for mounting the equipment must be placed and sized to ensure a safe and durable installation. See page 5 for hanging weights of the HSS® Air Handler units.

The HSS® Air Handler unit can only be located in a Vertical position, with a minimum clearance of 24 inches from the Blower Access Panel side of the Air Handler to avoid any obstruction. This clearance will allow blower and motor removal. The unit can be shelved in air or placed directly on the floor.

Location of the HSS® Air Handler unit will vary depending on the following: length of duct runs, usable floor space, serviceability and accessibility to the unit, minimizing structural changes, location of heating/cooling source, and available space in mechanical room.



**WARNING:** *When unit is installed over a finished ceiling and/ or living area, building codes may require a field supplied secondary condensate pan to be installed under the entire unit. Some localities may allow the alternative of running a separate secondary condensate line or applying a field mounted condensate overflow switch. Consult local codes for additional restrictions.*

**NOTE:** When installing any Air Handler over a finished ceiling and/ or living area, installation of a secondary drain pan under entire unit is recommended to avoid damage to ceiling.

## PRE START-UP

Before start-up, all of the components should be given a thorough check. Optimal operation of this equipment requires cleanliness. Often after installation of this equipment additional construction activities occur. Care must be taken to protect the equipment from debris during these construction phases. All access panels and filters must be in place before operation of the units.

## START-UP AND MAINTENANCE

**Fan:** The fan should be inspected and cleaned, in conjunction with maintenance of the motor and bearings. It is important to keep the wheels clean in order to avoid imbalance and vibration.

**Motor:** Check motor connections to ensure that they are secure and made in accordance with the wiring diagram. The blower motor should be cleaned annually.

**Filter:** The air filter should be cleaned or replaced every 30 days or more frequently if severe conditions exist. Always replace the filter with the same type as originally furnished.

**Coil:** Any dust or other contaminants which accumulate on the heat transfer surfaces interferes with the air flow and impairs heat transfer. The coil must be kept clean by any of the following methods:

1. Cleaning with low pressure compressed air.
2. Flushing or rinsing with water (a detergent is advisable for greasy surfaces).

**Drain Piping:** The condensate drain lines must be installed with adequate slope away from the unit to assure positive drainage. Since the drain pan is located on the suction side of the blower, a negative pressure exists at the drain pan and a minimum trap of 1-1/2 inches must be provided to the drain line to assure proper drainage. The drain should always be:

1. Connected or piped to an acceptable disposal point sloped away from the unit
2. Checked before summer operation
3. Periodically checked during summer operation



**WARNING:** *The HSS® Air Handler does not come with primary and secondary drain plugs installed.*

## PREVENTATIVE MAINTENANCE

To achieve maximum performance and service life of each piece of equipment a formal schedule of regular maintenance should be established.

It is also recommended to have a service contractor perform a system check in the spring for the cooling season, and in the fall for heating season.

# HSS® AIR HANDLER UNIT INFORMATION

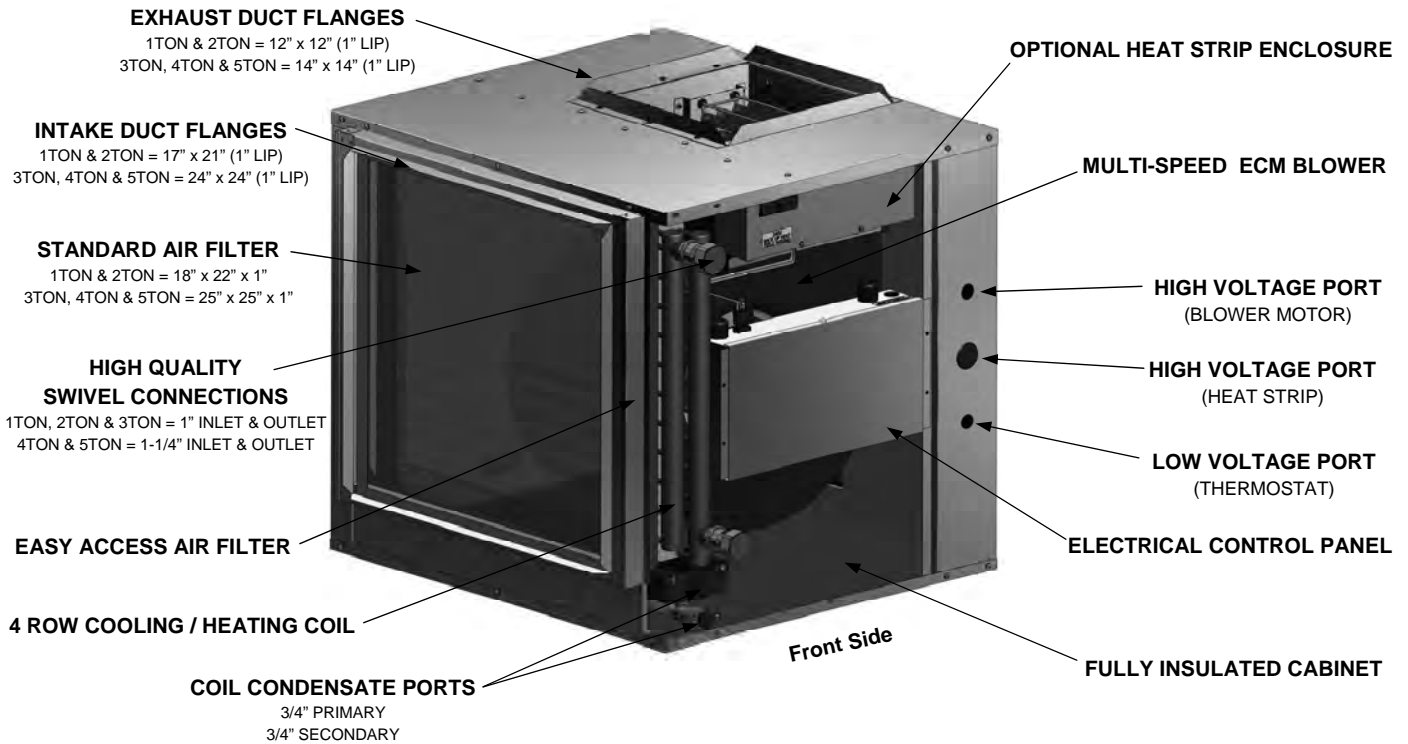

HSS® Air Handler with Left Side Configuration Shown

MODEL #	APPROX WT (LBS)	DIMENSIONS
BDAH-01	100	23"W x 24"H x 28"D
BDAH-02	105	23"W x 24"H x 28"D
BDAH-03	136	28"W x 30"H x 31"D
BDAH-04	146	28"W x 30"H x 31"D
BDAH-05	165	28"W x 30"H x 31"D

## HSS® AIR HANDLER MODEL NUMBER INFORMATION

BDAH-		E		-	1	A	U
<b>TONNAGE</b> 01 = 1 TON 02 = 2 TON 03 = 3 TON 04 = 4 TON 05 = 5 TON	<b>MOTOR TYPE</b> E = ECM	<b>CFM</b> 05 = 500CFM 1 TON 09 = 950CFM 2 TON 13 = 1350CFM 3 TON 17 = 1750CFM 4 TON 21 = 2150CFM 5 TON	<b>KW</b> 00 = None 03 = 3KW 05 = 5KW 10 = 10KW 15 = 15KW	<b>VOLTAGE</b> 1 = 240V / 208V 60Hz / 1Phase	<b>LEFT/RIGHT RETURN CONFIGURATION</b> A = Left (Standard) B = Right	<b>Air Flow Direction Configuration</b> U = Up flow (Standard) D = Down flow H = Horizontal Flow	
			<b>MAX KW /UNIT</b> 1 TON - 3KW 2 TON - 5KW 3 TON - 10KW 4 TON - 10KW or 15KW 5 TON - 10KW or 15KW	<b>NOTE:</b> This is the Side the Filter will be Located on.			

NOTE: Backup Heat not available on Horizontal Flow Units

# HSS® AIR HANDLER UNIT ACCESS

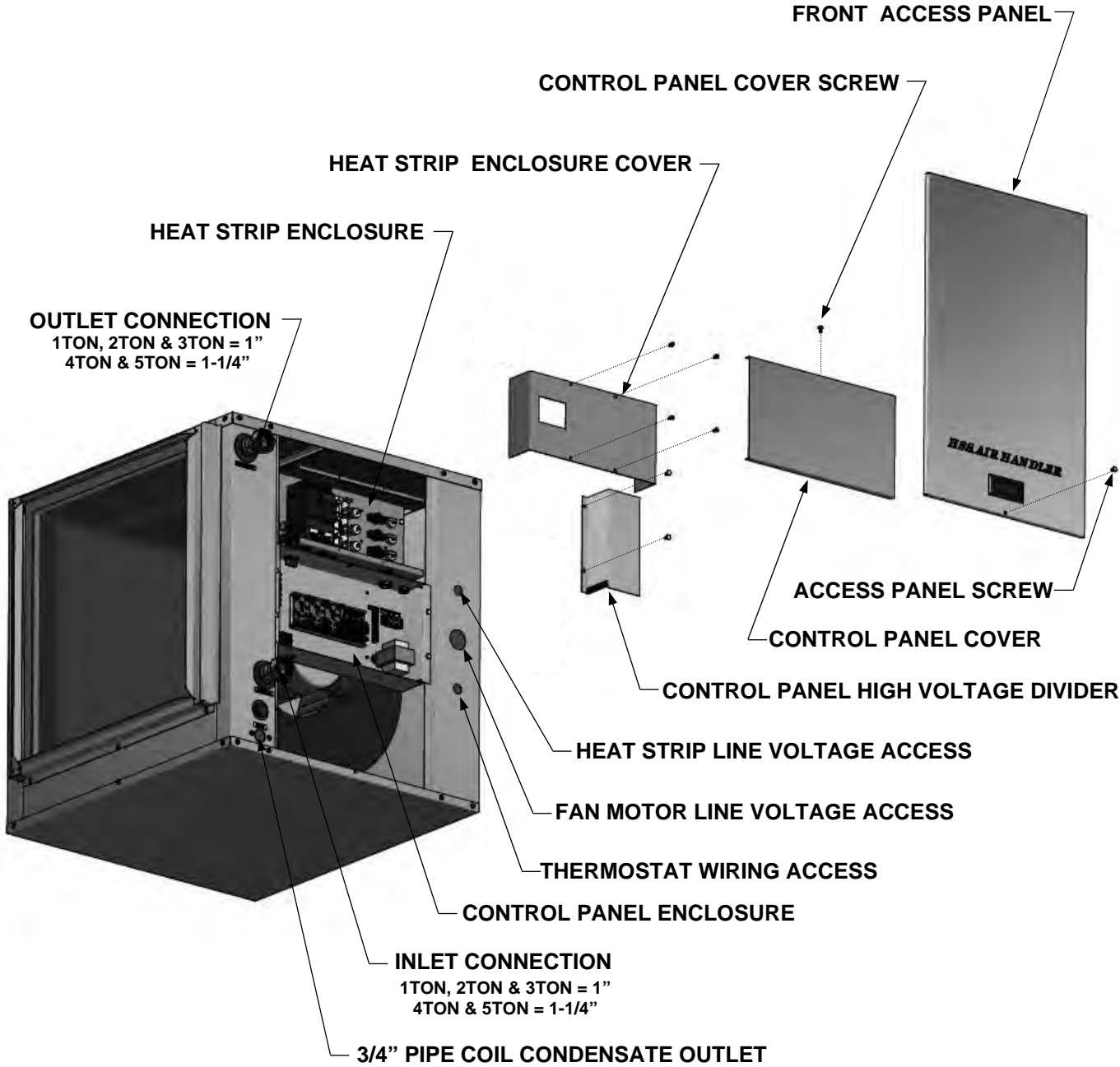



# ELECTRIC HEAT STRIP INSTALLATION PROCEDURE



**WARNING:** Only use electric heat strip components provided by B&D Mfg., Inc. The electric heat strip components are specially designed for the HSS® Air Handler. Any use of different components may not be a compatible fit and may cause harm to the unit and will void all warranty.

1. Disconnect power and lock out.
2. Remove bolt (8.1) from the front access panel (1)
3. Remove bolt (8.2) from the blower access panel (2)
4. Remove both access panels (1 & 2) by lifting up, then out and down.
5. Remove both inner plenum covers (4a & 4b), 4 bolts each (8.3 & 8.4).
6. Remove the 4 heat strip assembly cover screws (8.5) and heat strip assembly cover (6)
7. Press in the 4 heat strip coil frame end caps (7) into the heat strip frame support (9).
8. Slide heat strip assembly (5) through the heat strip access hole using the side access hole for assistance in lining up the heat strip frame ends, into the 4 coil frame end caps (7)
9. Bolt heat strip assembly (5) to the internal plenum (3) using the 4 bolts (8.3) from inner plenum cover (4a).
10. Bolt the inner plenum front cover (4b) onto the inner plenum using the 4 cover screws (8.4).
11. Plug in the 24V, 4 position control plug (10) to control box 4 position plug receptacle (11).
12. A separate 208V/240V power source is needed to supply power to the heat strip from a/# power source
13. After the heat strip is powered replace the heat strip assembly cover (6) with the 4 screws (8.5).
14. Replace both access panels (1 & 2) with bolts (8.1 & 8.2).

**NOTE: Inner plenum cover (4a) is no longer needed**

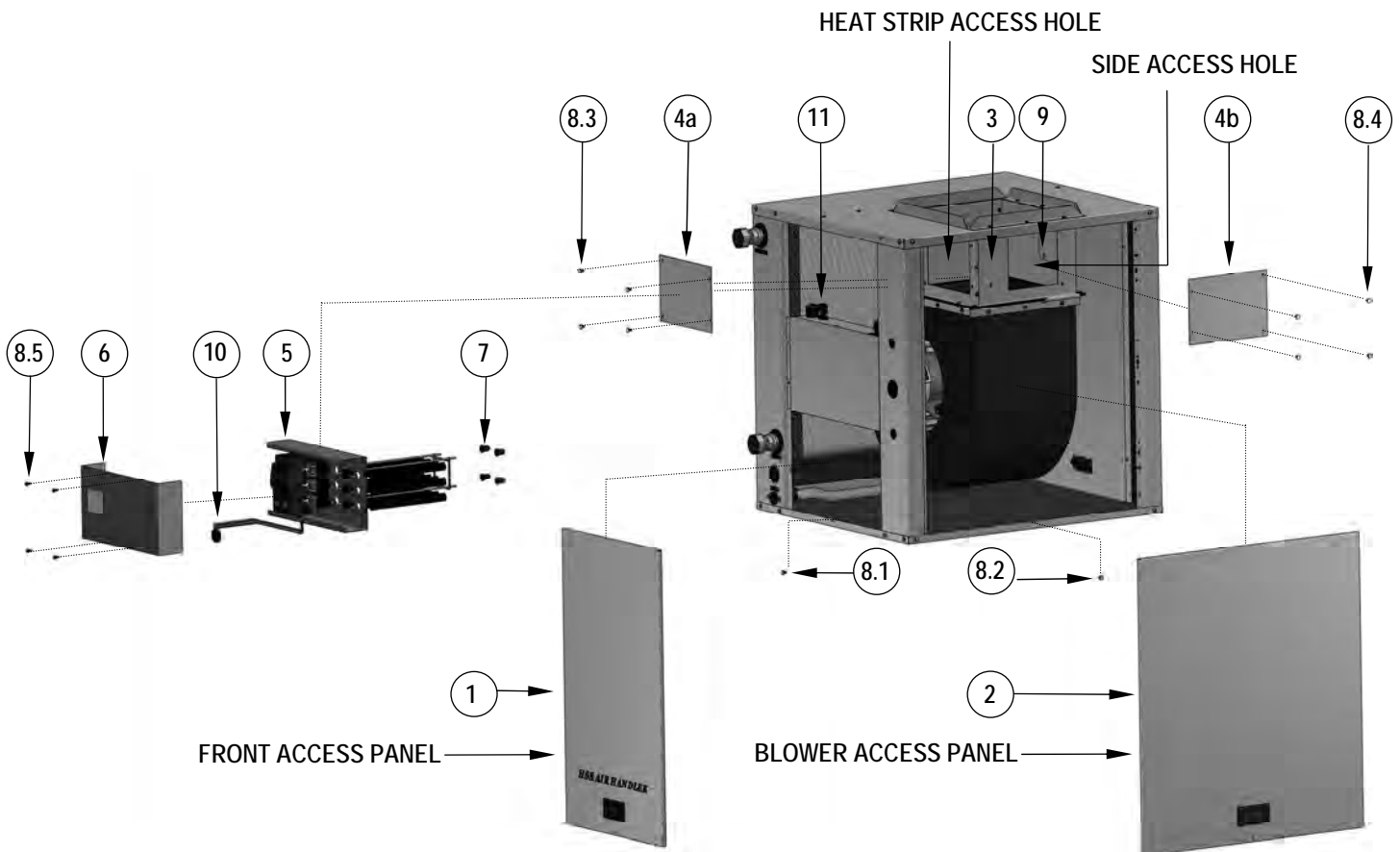

# EMERGENCY HEAT SEQUENCE OF OPERATION

## Emergency Heat Sequence of Operation on “W” Call

### 15KW

“W” Call comes from the thermostat for emergency heat:

- Fan comes on w/30 second ramp up time to full speed, which is factory programmed into the ECM motor.
- First 5kw of heat strip come on immediately with the “W” call.
- After 30 seconds, the second 5kw of the heat strip, comes on through “Heat Timer 2” which is factory preset but can be field adjustable from .5 – 35 minutes.

If within 5 minutes of the initial “W” call, the call is satisfied the heat strip will shut down w/30 second ramp down speed which is factory programmed into the ECM Motor.

- If after 5 minutes of the initial “W” call, the call is not satisfied, the third 5kw of the heat strip will come on through “Heat Timer 3” which is factory preset for a 5 minute delay but can be field adjustable from .5 – 35 minutes.

When the “W” call is satisfied:

- The entire 15kw heat strip will shut down.
- The fan will shut down w/30 second ramp down to off

### 10KW

“W” Call comes from the thermostat for emergency heat:

- Fan comes on w/30 second ramp up time to full speed, which is factory programmed into the ECM motor.
- First 5kw of heat strip come on immediately with the “W” call.
- After 30 seconds the second 5kw of the heat strip comes on through “Heat Timer 2” which is factory preset but can be field adjustable from .5 – 35 minutes.

When the “W” call is satisfied:

- The entire 10kw heat strip will shut down.
- The fan will shut down w/30 second ramp down to off

### 5KW

“W” Call comes from the thermostat for emergency heat:

- Fan comes on w/30 second ramp up time to full speed, which is factory programmed into the ECM motor.
- The heat strip comes on immediately with the W call

When the “W” call is satisfied:

- The entire 15kw heat strip will shut down.
- The fan will shut down w/30 second ramp down to off

## Fan Sequence of Operation on “Y” Call

“Y” Call comes from the thermostat for heat or cooling:

- Fan timer is activated w/30 second delay which is factory preset but can be field adjustable from .5 – 35 minutes.
- After the timer delay of 30 seconds, the fan comes on w/30 second ramp up time to full speed, which is factory programmed into the ECM motor.

When the “Y” call is satisfied;

- The fan will shut down w/30 second ramp down to off.

# ELECTRICAL DATA INFORMATION SHEET

## All Models without Emergency Backup Heat

Model No Heat Strip	Motor / Load	MCA	MOP
Model BDAH-01	1/3hp / 2.6	3.25	15
Model BDAH-02	1/3hp / 2.6	3.25	15
Model BDAH-03	1/2hp / 4.6	5.75	15
Model BDAH-04	1/2hp / 4.6	5.75	15
Model BDAH-05	1hp / 7	8.75	15

## Model BDAH-01 3kw Emergency Heat Strip

Model With Heat Strip	kW / Load	MCA	MOP
Model BDAH-01	3kW / 12.5	15.63	20

## Model BDAH-02 5kw Emergency Heat Strip

Model With Heat Strip	kW / Load	MCA	MOP
Model BDAH-02	5kW / 20.8	26	30

## Model BDAH-03 10kw Emergency Heat Strip

Model With Heat Strip	kW / Load	MCA	MOP
Model BDAH-03	10kW / 41.7	52.125	60

## Model BDAH-04 10kw or 15kw Emergency Heat Strip

Model With Heat Strip	kW / Load	MCA	MOP
Model BDAH-04	10kW / 41.7	52.125	60
Model BDAH-04	15kW / 62.5	78.125	80

## Model BDAH-05 10kw or 15kw Emergency Heat

Model With Heat Strip	kW / Load	MCA	MOP
Model BDAH-05	10kW / 41.7	52.125	60
Model BDAH-05	15kW / 62.5	78.125	80

# HSS® AIR HANDLER PIPING DIAGRAM & PIPING CONNECTIONS

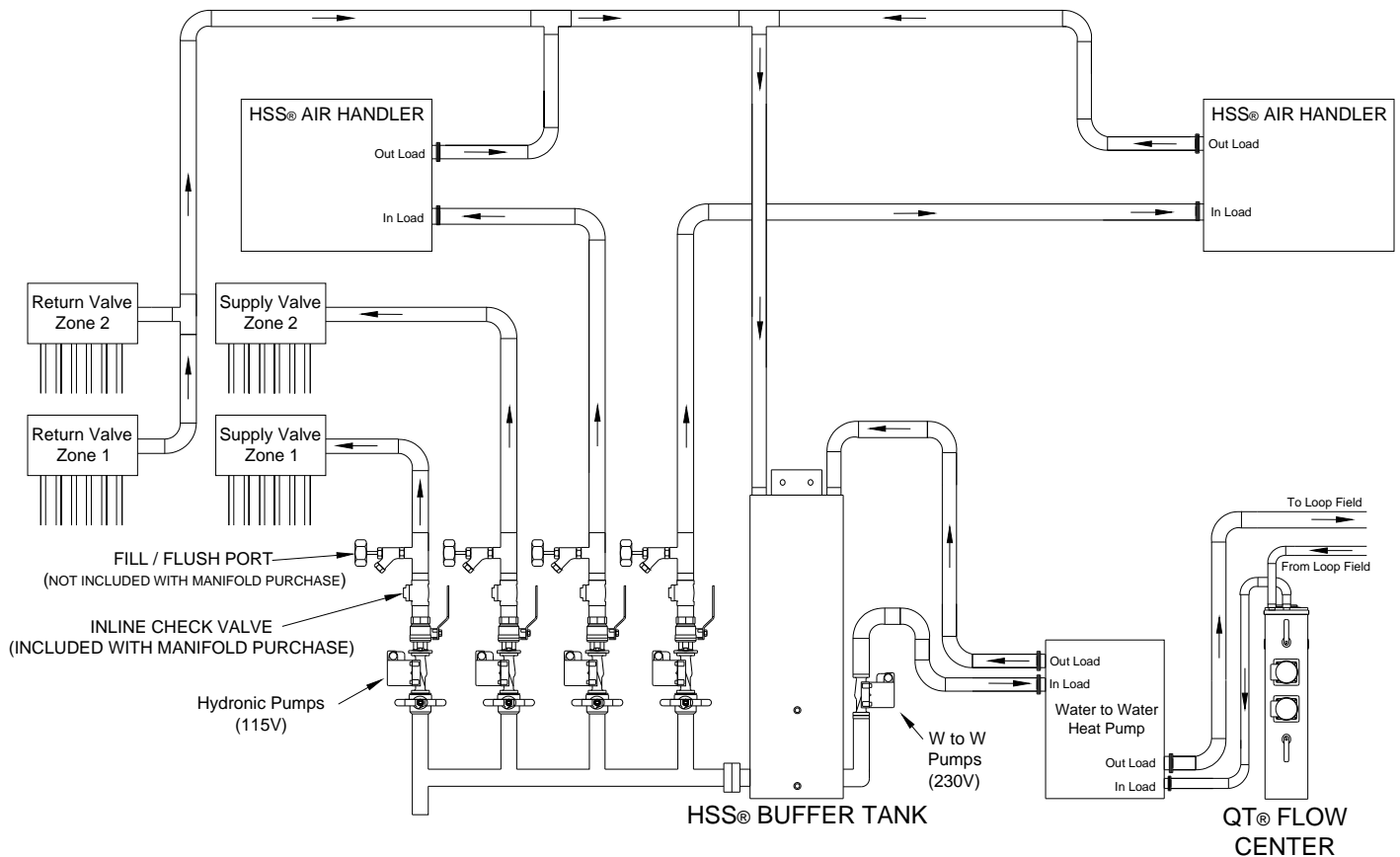

**1 TON 2 TON 3 TON  
HSS® AIR HANDLER  
PIPING CONNECTIONS**

**4 TON & 5 TON  
HSS® AIR HANDLER  
PIPING CONNECTIONS**

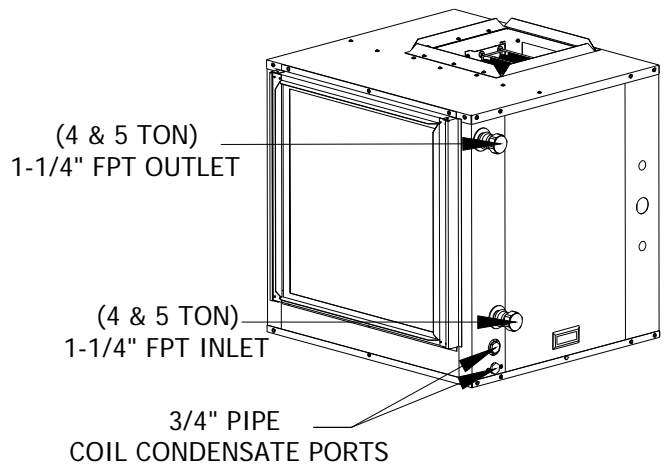
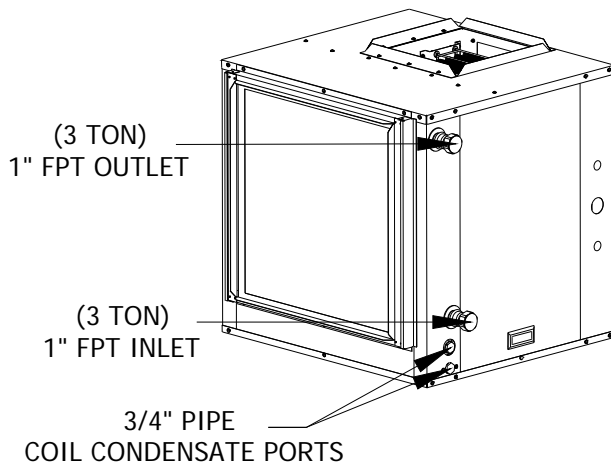

# 1 TON & 2 TON HSS® AIR HANDLER WIRING SCHEMATIC

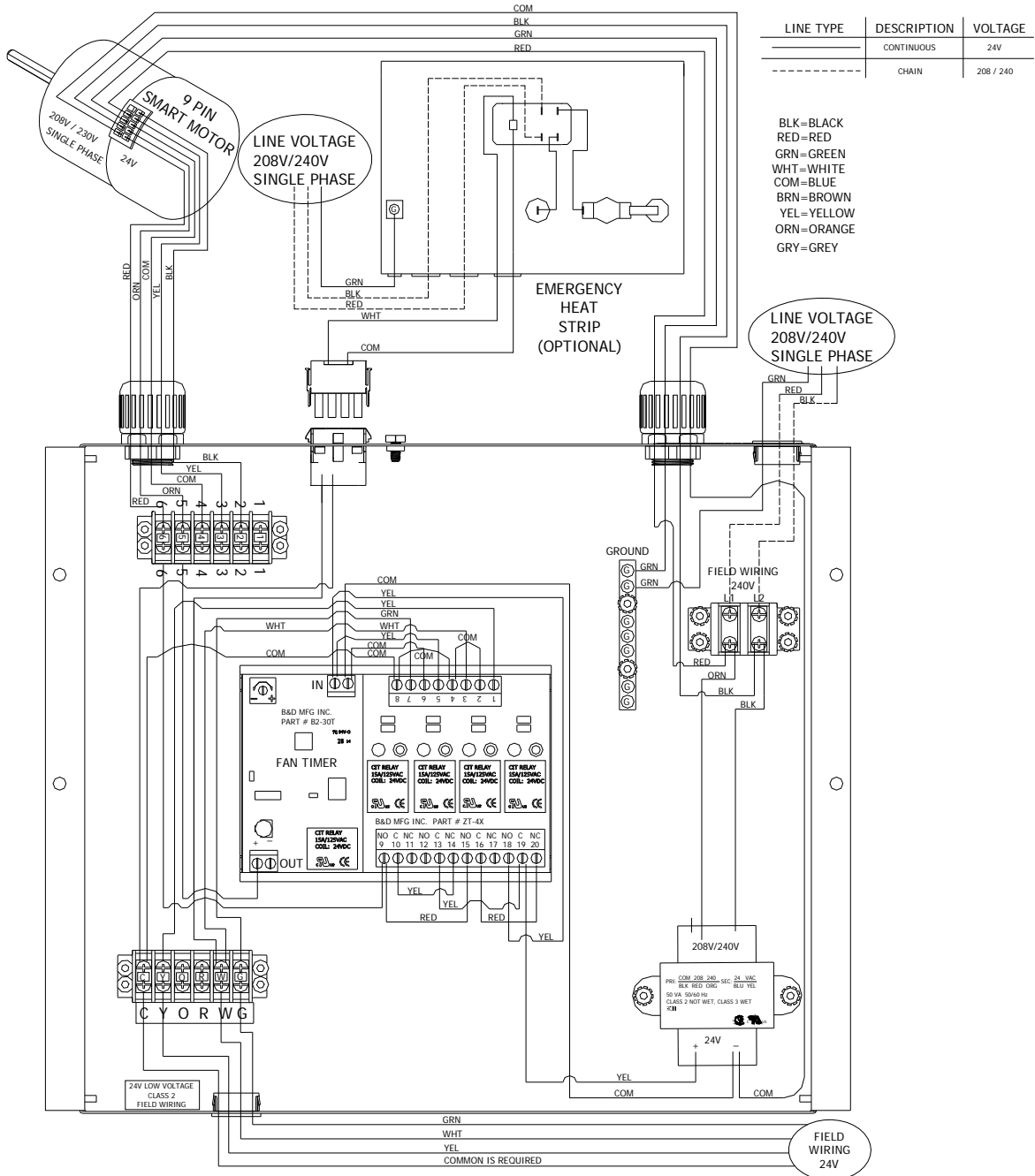

- ALL FIELD WIRING MUST BE PER THE FOLLOWING:
  - NATIONAL ELECTRICAL CODE (NEC) AND / OR
  - CANADIAN ELECTRICAL CODE (CEC) AND / OR
  - STATE, COUNTY, LOCAL, REGIONAL OR CITY CODES.
- IF ANY OF THE ORIGINAL WIRING MUST BE REPLACED; REPLACE THE WIRE WITH WIRE THAT HAS THE SAME TEMPERATURE RATING OF 221~F (105~C).
- ONLY USE COPPER CONDUCTORS FOR FIELD WIRING.
- ALL REPLACEMENT COMPONENTS MUST BE PROPERLY GROUNDED.
- PROVIDE CIRCUIT BREAKER SIZED TO PROTECT THE WIRING FROM THE MAIN ELECTRICAL SERVICE ENTRANCE TO THE CIRCUIT BREAKERS IN THE UNIT CONTROL BOX.
- THE MOTORS ARE INTERNALLY THERMALLY PROTECTED.
- THE COMMON WIRE FROM THE THERMOSTAT IS REQUIRED

# 3 TON, 4 TON & 5 TON HSS® AIR HANDLER WIRING SCHEMATIC

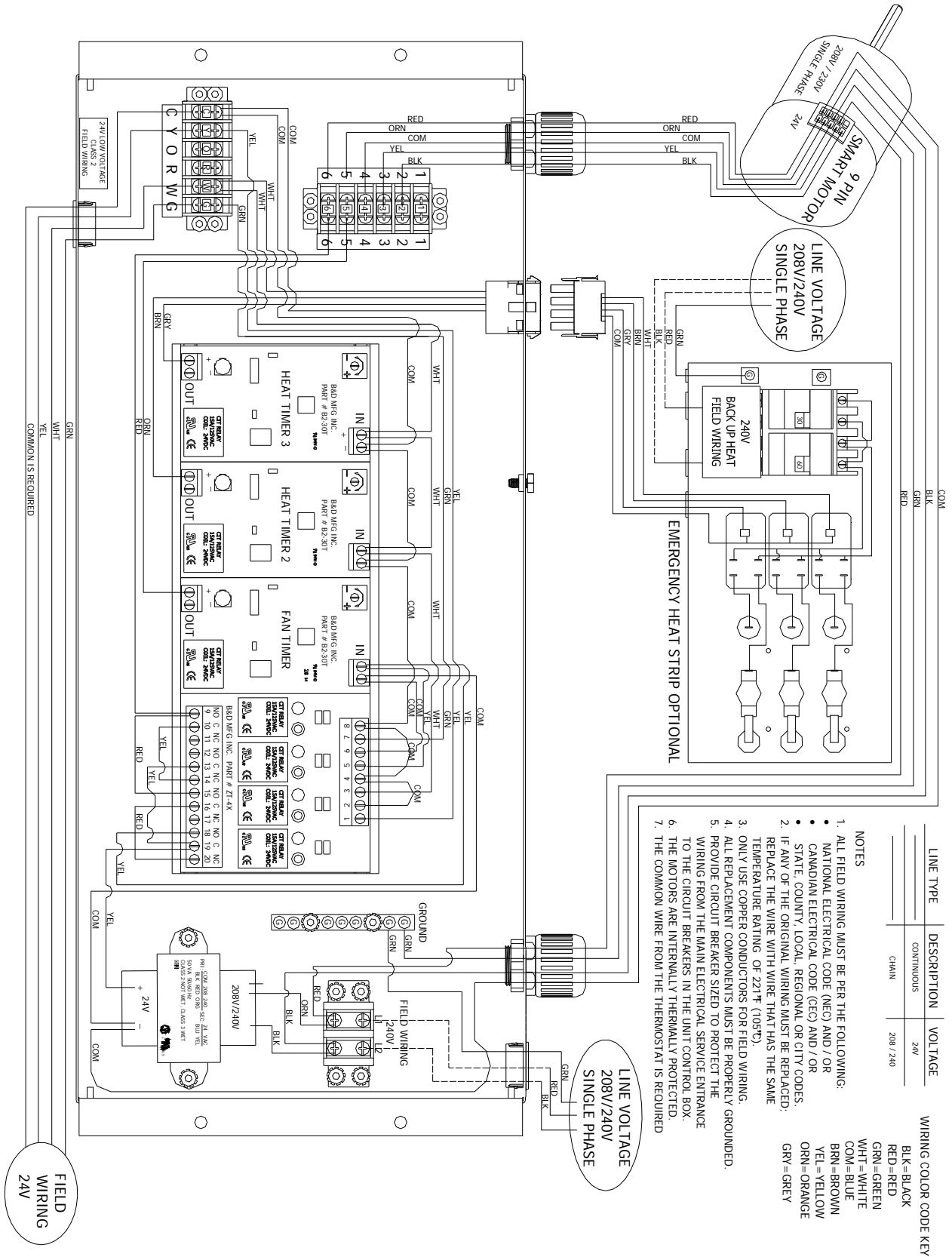

LINE TYPE	DESCRIPTION	VOLTAGE
CONTINUOUS		24V
CHAM		208 / 240

**NOTES**

1. ALL FIELD WIRING MUST BE PER THE FOLLOWING:
  - NATIONAL ELECTRICAL CODE (NEC) AND / OR
  - CANADIAN ELECTRICAL CODE (CEC) AND / OR
  - STATE, COUNTY, LOCAL, REGIONAL OR CITY CODES.
 IF ANY OF THE ORIGINAL WIRING MUST BE REPLACED:
  - REPLACE THE WIRE WITH WIRE THAT HAS THE SAME TEMPERATURE RATING OF 2217F (1095D).
2. ONLY USE COPPER CONDUCTORS FOR FIELD WIRING.
3. ALL REPLACEMENT COMPONENTS MUST BE PROPERLY GROUNDED.
4. PROVIDE CIRCUIT BREAKER SIZED TO PROTECT THE WIRING FROM THE MAIN ELECTRICAL SERVICE ENTRANCE TO THE CIRCUIT BREAKERS IN THE UNIT CONTROL BOX.
5. THE MOTORS ARE INTERNALLY THERMALLY PROTECTED.
6. THE COMMON WIRE FROM THE THERMOSTAT IS REQUIRED

**WIRING COLOR CODE KEY**

- BLK=BLACK
- RED=RED
- GRN=GREEN
- WHT=WHITE
- COM=BLUE
- BRN=BROWN
- YEL=YELLOW
- ORN=ORANGE
- GRY=GREY



# 1 TON 2 TON SPEED TERMINAL LUG ASSIGNMENT

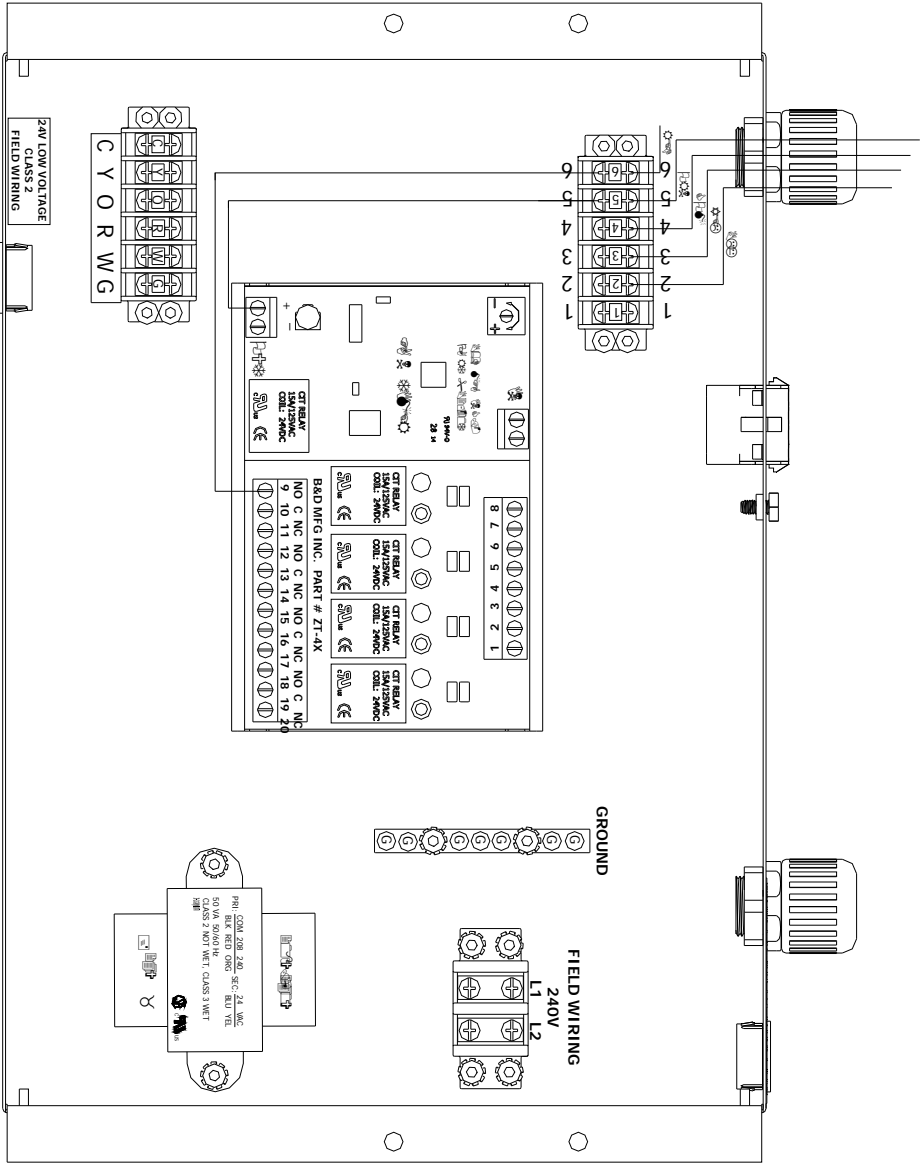

1 Ton Unit	Torque (oz / ft)	Speed (RPM)	Air Flow (CFM)	Rated / Max ESP
Lug 2	5	850	270	.15 / .5
Lug 3	7	980	330	.3 / .5
Lug 4	9	1020	390	.3 / .5
Lug 5	11	1080	440	.3 / .5

2 Ton Unit	Torque (oz / ft)	Speed (RPM)	Air Flow (CFM)	Rated / Max ESP
Lug 2	11.6	975	600	.3 / .5
Lug 3	13	1015	700	.3 / .5
Lug 4	15	1060	800	.3 / .5
Lug 5	19	1120	950	.3 / .5

## MOTOR TAPS / CONTROL TERMINAL LUG

POSITION ONLY THE ORANGE (ORN) WIRE FOR DESIRED PRE-PROGRAMMED AIR FLOW



# 3 TON, 4 TON & 5 TON SPEED TERMINAL LUG ASSIGNMENT

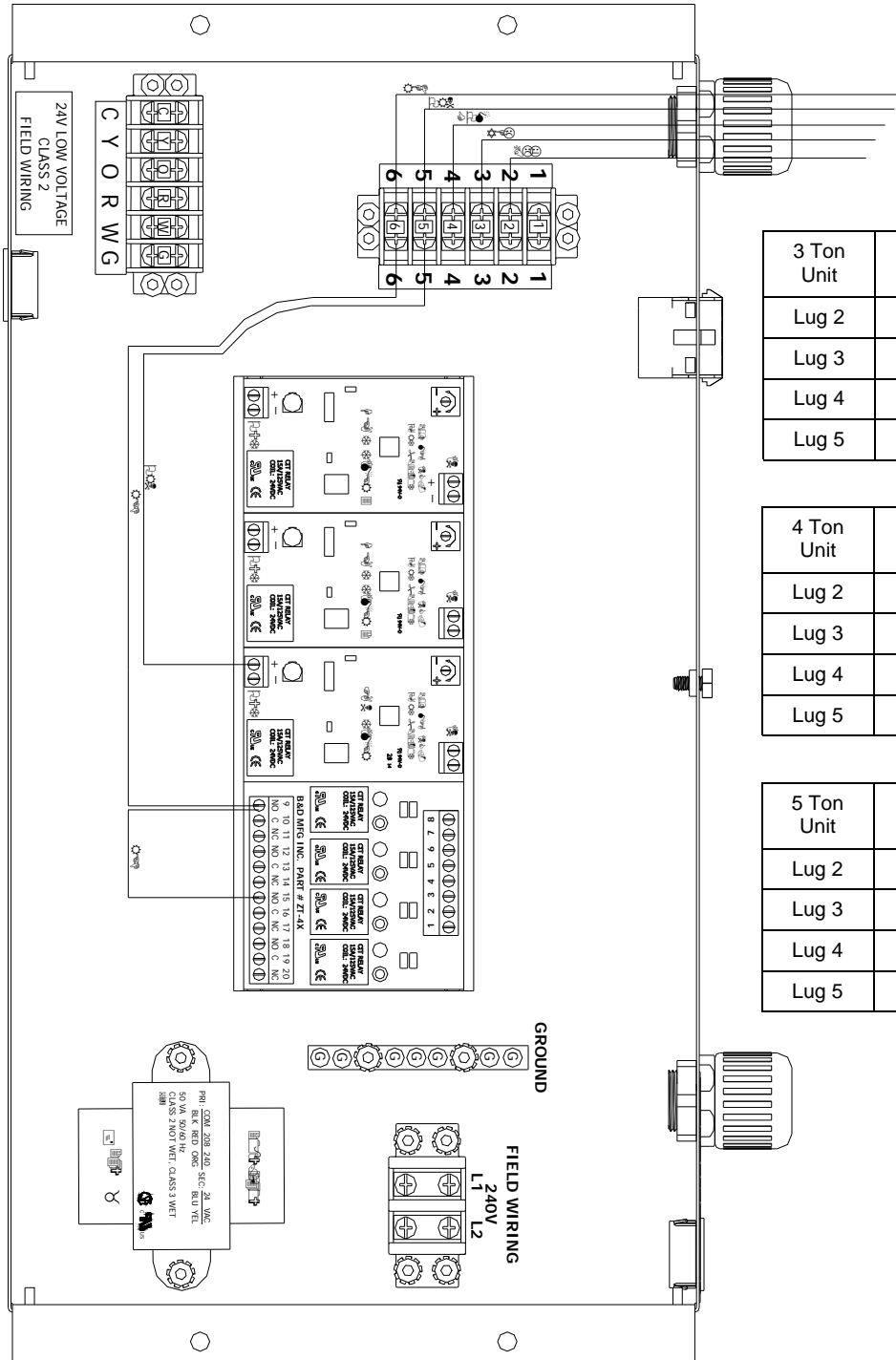

3 Ton Unit	Torque (oz / ft)	Speed (RPM)	Air Flow (CFM)	Rated / Max ESP
Lug 2	23	970	1000	.3 / .5
Lug 3	24.2	980	1100	.3 / .5
Lug 4	26.5	1005	1200	.3 / .5
Lug 5	28.5	1023	1350	.3 / .5

4 Ton Unit	Torque (oz / ft)	Speed (RPM)	Air Flow (CFM)	Rated / Max ESP
Lug 2	24	939	1400	.3 / .5
Lug 3	28.9	1023	1500	.3 / .5
Lug 4	31.3	1083	1600	.3 / .5
Lug 5	37.3	1104	1750	.3 / .5

5 Ton Unit	Torque (oz / ft)	Speed (RPM)	Air Flow (CFM)	Rated / Max ESP
Lug 2	43	860	1800	.3 / .5
Lug 3	47	872	1900	.3 / .5
Lug 4	50	890	2000	.3 / .5
Lug 5	57.5	925	2150	.3 / .5

## MOTOR TAPS / CONTROL TERMINAL LUG

POSITION ONLY THE ORANGE (ORN) WIRE FOR DESIRED PRE-PROGRAMMED AIR FLOW



# HSS® AIR HANDLER TO HSS® BUFFER TANK WIRING

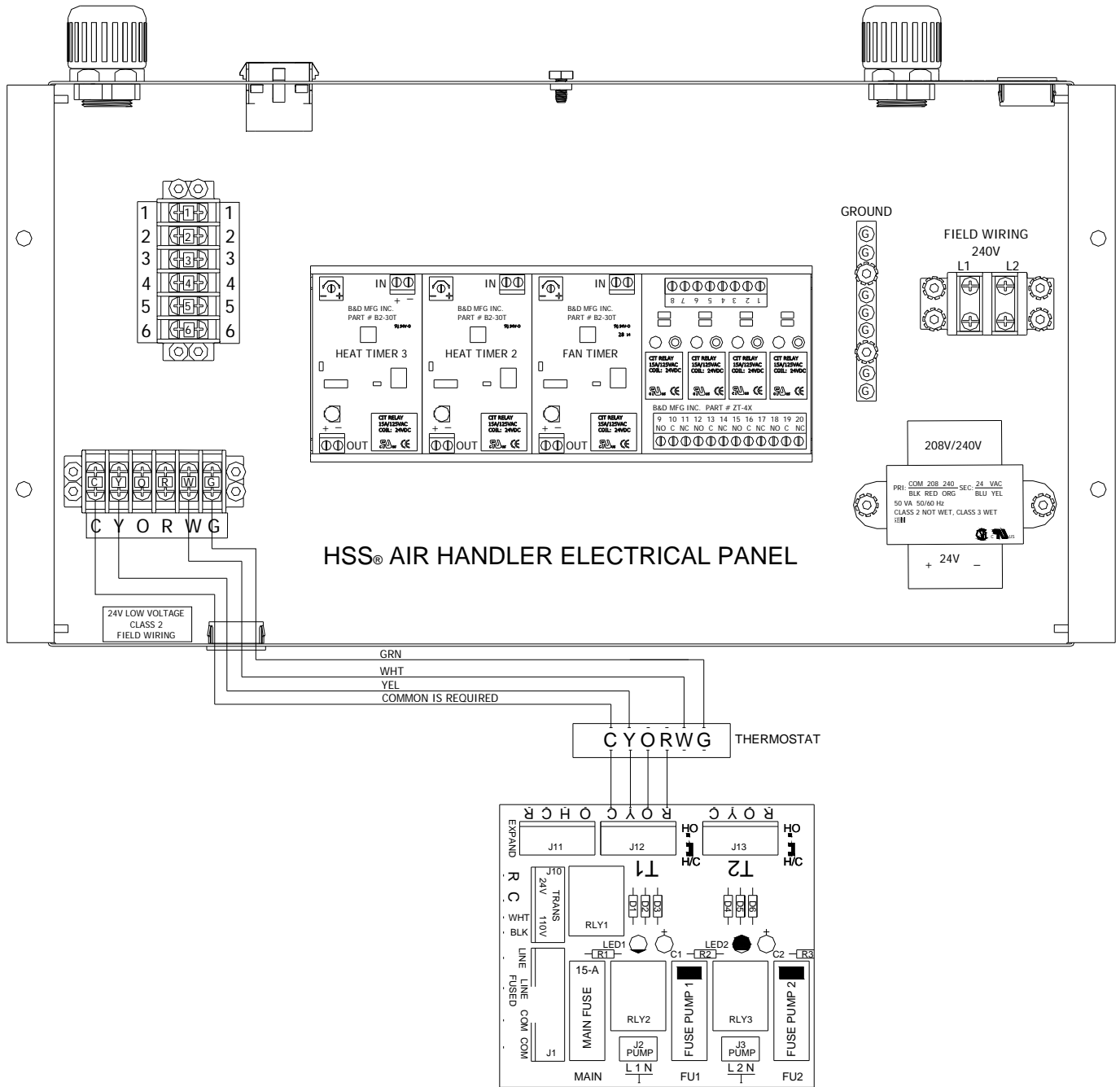

HSS® BUFFER TANK B3-6CR BOARD

# Model BDAH-01 Cooling Data

CFM	P.D. (ft. H2O)	GPM	40°F Entering Water						45°F Entering Water						50°F Entering Water						
			75°F DB/63°F WB Entering Air			80°F DB/67°F WB Entering Air			75°F DB/63°F WB Entering Air			80°F DB/67°F WB Entering Air			75°F DB/63°F WB Entering Air			80°F DB/67°F WB Entering Air			
			Total MB/H	Sens. MB/H	Exit H2O°F	Total MB/H	Sens. MB/H	Exit H2O°F	Total MB/H	Sens. MB/H	Exit H2O°F	Total MB/H	Sens. MB/H	Exit H2O°F	Total MB/H	Sens. MB/H	Exit H2O°F	Total MB/H	Sens. MB/H	Exit H2O°F	
300	2.6	2	10.1	7.7	50	12	8.5	52	8.3	6.9	53.2	10.2	7.7	55.1	6.6	6.2	56.6	8.3	7	58.3	
			12.3	8.7	46.1	15	9.8	47.5	10	7.7	50	12.5	8.7	51.2	7.7	6.7	53.8	10.1	7.7	55	
	9.5	4	4	10.7	8.5	50.7	12.8	9.3	52.7	8.9	7.7	53.8	10.8	8.5	55.8	7.1	6.8	57.1	8.9	7.8	58.9
				13.4	9.7	46.6	16.2	10.8	48	10.9	8.6	50.4	13.6	9.7	51.8	8.4	7.5	54.2	10.9	8.6	55.5
	350	9.5	4	13.4	9.7	46.6	16.2	10.8	48	10.9	8.6	50.4	13.6	9.7	51.8	8.4	7.5	54.2	10.9	8.6	55.5
				11.3	9.2	51.2	13.4	10.1	53.3	9.3	8.3	54.3	11.4	9.3	56.4	7.6	7.4	57.6	9.4	8.4	59.4
	400	2.6	2	14.2	10.6	47.1	17.2	11.7	48.5	11.6	9.4	50.8	14.4	10.6	52.2	9	8.3	54.5	11.6	9.5	55.8
				14.2	10.6	47.1	17.2	11.7	48.5	11.6	9.4	50.8	14.4	10.6	52.2	9	8.3	54.5	11.6	9.5	55.8
	400	9.5	4	14.2	10.6	47.1	17.2	11.7	48.5	11.6	9.4	50.8	14.4	10.6	52.2	9	8.3	54.5	11.6	9.5	55.8
				12.2	10.4	52.1	14.4	11.4	54.3	10.2	9.5	55.2	12.3	9.4	57.2	8.1	8.1	58.1	10.3	9.6	60.3
	500	9.5	4	15.6	12.1	47.8	18.8	13.4	49.3	12.8	10.9	51.4	15.8	12.2	52.9	10.1	9.6	55	12.8	11	56.4
				9.5	7.4	49.6	11.3	8.2	51.5	7.8	6.7	52.9	9.5	7.5	54.7	6.3	6	56.4	7.8	6.8	58
300	2.5	2	11.8	8.5	46	14.3	9.5	47.3	9.6	7.5	49.9	12	8.5	51.1	7.4	6.6	53.8	9.7	7.6	54.9	
			10.2	8.2	50.2	11.9	9	52.1	8.3	7.4	53.5	10.1	8.3	55.3	6.8	6.6	56.9	8.4	7.5	58.5	
350	10.2	4	12.8	9.4	46.5	15.4	10.5	47.8	10.4	8.4	50.3	12.9	9.4	51.6	8.1	7.4	54.1	10.4	8.4	55.3	
			10.6	8.8	50.7	12.5	9.7	52.7	8.8	8	53.9	10.6	9	55.8	7	7	57.1	8.8	8.2	59	
400	2.5	2	13.6	10.3	46.9	16.3	11.4	48.3	11.1	9.2	50.6	13.7	10.3	52	8.6	8.1	54.4	11.1	9.2	55.6	
			10.2	10.3	46.9	16.3	11.4	48.3	11.1	9.2	50.6	13.7	10.3	52	8.6	8.1	54.4	11.1	9.2	55.6	
400	10.2	4	13.6	10.3	46.9	16.3	11.4	48.3	11.1	9.2	50.6	13.7	10.3	52	8.6	8.1	54.4	11.1	9.2	55.6	
			10.6	8.8	50.7	12.5	9.7	52.7	8.8	8	53.9	10.6	9	55.8	7	7	57.1	8.8	8.2	59	
500	2.5	2	11.3	10	51.5	13.4	11	53.6	9.6	9.1	54.7	11.4	10.2	56.6	7.7	7.7	57.8	9.7	9.2	59.8	
			14.9	11.7	47.6	17.8	12.9	49	12.2	10.6	51.2	15	11.8	52.6	9.7	9.4	54.9	12.2	10.7	56.2	
300	2.1	2	8.9	7.2	49.2	10.6	7.9	51	7.4	6.5	52.7	9.1	7.3	54.4	5.6	5.8	56.1	7.4	6.6	57.6	
			11.3	8.3	45.8	13.6	9.2	47	9.2	7.4	49.8	11.5	8.3	50.9	7.1	6.5	53.7	9.3	7.4	54.8	
300	10.1	4	11.3	8.3	45.8	13.6	9.2	47	9.2	7.4	49.8	11.5	8.3	50.9	7.1	6.5	53.7	9.3	7.4	54.8	
			9.5	7.9	49.8	11.2	8.7	51.6	7.9	7.2	53.2	9.6	8	54.9	6.2	6.2	56.4	7.9	7.3	58.1	
350	10.1	4	12.2	9.2	46.3	14.6	10.1	47.5	9.9	8.2	50.1	12.3	9.2	51.4	7.8	7.3	54	10	8.3	55.1	
			9.9	8.6	50.2	11.7	9.4	52.1	8.4	7.8	53.6	9.9	8.6	55.2	6.6	6.6	56.8	8.3	7.9	58.6	
400	2.2	2	12.9	10	46.7	15.4	11	48	10.5	8.9	50.4	13	10	51.7	8.3	7.9	54.3	10.6	9	55.5	
			10.1	10	46.7	15.4	11	48	10.5	8.9	50.4	13	10	51.7	8.3	7.9	54.3	10.6	9	55.5	
400	10.1	4	12.9	10	46.7	15.4	11	48	10.5	8.9	50.4	13	10	51.7	8.3	7.9	54.3	10.6	9	55.5	
			9.9	8.6	50.2	11.7	9.4	52.1	8.4	7.8	53.6	9.9	8.6	55.2	6.6	6.6	56.8	8.3	7.9	58.6	
500	2.2	2	10.6	9.7	51	12.5	10.6	52.9	9.1	8.8	54.4	10.7	9.8	56	7.2	7.2	57.5	9.1	8.9	59.4	
			14	11.4	47.2	16.8	12.5	48.7	11.6	10.3	51	14.2	11.5	52.3	9.3	9.2	54.8	11.6	10.4	56	



# Model BDAH-01 Heating Data

	CFM	P.D. (Ft. H2O)	GPM	105°F Entering Water		110°F Entering Water		115°F Entering Water	
				70°F Entering Air		70°F Entering Air		70°F Entering Air	
				Total MB/H	Exit H2O°F	Total MB/H	Exit H2O°F	Total MB/H	Exit H2O°F
Heating Capacities based upon 0% Glycol	300	2.4	2	9.1	95.8	10.4	99.5	11.8	103.1
		8.5	4	10	100	11.4	104.2	12.9	108.5
	350	2.4	2	9.8	94.9	11.4	98.4	12.9	102
		8.5	4	11.2	99.4	12.8	103.5	14.4	107.7
	400	2.4	2	10.7	94.2	12.3	97.6	13.9	101
		8.5	4	12.2	98.8	14	102.9	15.8	107
500	2.4	2	12	92.9	13.8	96.1	15.5	99.3	
	8.5	4	14	97.9	16.1	101.9	18.1	105.8	
Heating Capacities based upon 10% Glycol	300	2.5	2	8.9	96	10.2	99.6	11.5	103.3
		8.9	4	9.9	100	11.3	104.3	12.7	108.5
	350	2.5	2	9.7	95.2	11.1	98.7	12.6	102.2
		8.9	4	10.9	99.4	12.6	103.6	14.2	107.8
	400	2.5	2	10.4	94.4	11.9	97.9	13.5	101.3
		9	4	12	98.9	13.7	103	15.5	107.1
	500	2.5	2	11.5	93.3	13.3	96.5	15	99.7
		9	4	13.7	98	15.7	102	17.7	106
Heating Capacities based upon 20% Glycol	300	2.6	2	8.5	96.2	9.8	99.9	11.1	103.6
		9.4	4	9.7	100	11.1	104.3	12.5	108.6
	350	2.6	2	9.3	95.5	10.7	99	12.1	102.6
		9.4	4	10.8	99.5	12.4	103.6	13.9	107.8
	400	2.6	2	9.9	94.8	11.4	98.3	12.9	101.7
		9.4	4	11.7	99	13.5	103.1	15.2	107.2
	500	2.6	2	10.9	93.8	12.6	97	14.2	100.3
		9.4	4	13.4	98.1	15.3	102.1	17.3	106.1

## Electric Heat Strip Information

PART#	DESCRIPTION
AH3KWHEAT	3KW ELECTRIC STRIP HEAT

## Electric Heat Strip Capacities

KW		BTU/H		TOTAL AMPS	
240V	208V	240V	208V	240V	208V
3KW	2.25KW	10236 BTU/H	7677 BTU/H	12.5 AMPS	10.81 AMPS

**NOTE:** The above listed heat strip part numbers and heat strip capacities data is only for the HSS® Air Handlers. These are specially designed for the electrical heat strip units for B&D Mfg., Inc. The electrical heat strip units are factory installed if ordered with electrical heat strip and can be field installed also if ordered without electrical heat strip.

# Model BDAH-02 Cooling Data

CFM	P.D. (ft. H2O)	GPM	40°F Entering Water						45°F Entering Water						50°F Entering Water						
			75°F DB/63°F WB Entering Air			80°F DB/67°F WB Entering Air			75°F DB/63°F WB Entering Air			80°F DB/67°F WB Entering Air			75°F DB/63°F WB Entering Air			80°F DB/67°F WB Entering Air			
			Total MB/H	Sens. MB/H	Exit H2O°F	Total MB/H	Sens. MB/H	Exit H2O°F	Total MB/H	Sens. MB/H	Exit H2O°F	Total MB/H	Sens. MB/H	Exit H2O°F	Total MB/H	Sens. MB/H	Exit H2O°F	Total MB/H	Sens. MB/H	Exit H2O°F	
600	1.4	3	19.6	15.2	53	23.3	16.7	55.5	16.3	13.7	55.9	19.9	15.3	58.2	13.2	12.3	58.8	16.4	13.9	61	
			25.1	17.7	48.4	30.4	19.8	50.1	20.5	15.7	51.8	25.6	17.7	53.5	15.8	13.7	55.3	20.7	15.7	56.9	
	5.8	6	20.9	16.8	53.9	24.7	18.4	56.5	17.5	15.5	56.6	21.2	16.9	59.1	14.3	13.6	59.5	17.6	15.5	61.8	
			27.3	19.7	49.1	32.9	21.9	50.9	22.3	17.5	52.4	27.7	19.7	54.2	17.3	15.4	55.8	22.5	17.6	57.5	
	700	1.4	3	22	18.1	54.6	26	19.9	57.3	18.5	16.5	57.3	22.3	18.4	59.8	14.3	14.3	59.6	18.7	16.8	62.5
				29.1	21.5	49.7	35	23.9	51.6	23.8	19.2	52.9	29.5	21.6	54.8	18.7	17	56.2	24	19.4	58
800	5.8	6	23.3	19.9	55.5	27.4	21.9	58.2	19.8	18.1	58.2	23.6	20.2	60.7	15.4	15.4	60.3	20.1	18.5	63.4	
			31.4	24	50.4	37.6	26.5	52.5	25.8	21.5	53.6	31.8	24.1	55.5	20.5	19.2	56.8	26.1	21.8	58.7	
950	1.3	3	18.1	14.5	52.3	21.4	15.9	54.5	15.1	13.2	55.3	18.3	14.7	57.4	12.3	11.8	58.4	15.2	13.4	60.4	
			23.8	17.1	48.1	28.6	19	49.7	19.4	15.2	51.6	24.1	17.1	53.2	15.1	13.3	55.1	19.5	15.3	56.6	
	6.2	6	19.2	16	53	22.7	17.5	55.4	16.2	14.6	56	19.4	16.2	58.2	12.6	12.6	58.5	16.3	14.8	61.1	
			25.7	19	48.7	30.8	21	50.5	21	17	52.1	26	19	53.8	16.5	15	55.6	21.1	17.1	57.2	
	700	1.3	3	20.1	17.3	53.7	23.7	18.9	56.1	17.1	15.8	56.6	20.4	17.6	58.9	13.3	13.3	59.1	17.3	16.1	61.8
				27.3	20.7	49.3	32.7	22.9	51.1	22.4	18.6	52.6	27.6	20.8	54.4	17.7	16.5	56	22.6	18.8	57.7
800	6.2	6	21.3	18.9	54.4	24.9	20.8	56.9	18.2	17.2	57.3	21.6	19.3	59.6	14.3	14.3	59.7	17.8	17.3	62.1	
			29.3	23	49.9	35.1	25.4	51.8	24.2	20.8	53.2	29.6	23.2	55	19.4	18.6	56.6	24.4	21.1	58.2	
950	1.5	3	16.6	13.9	53.9	19.6	15.2	53.5	13.9	12.6	54.6	16.7	14	56.5	10.8	11.6	57.5	14	12.9	59.7	
			22.3	16.4	47.7	26.7	18.2	49.2	18.3	14.7	51.3	22.6	16.5	52.8	14.3	13	55	18.4	14.8	56.4	
	5.8	6	17.5	15.2	52.1	20.6	16.7	54.2	14.8	13.9	55.2	17.7	15.5	57.2	10.8	11.6	58	15	14.1	60.3	
			23.9	18.2	48.3	28.6	20.1	49.9	19.7	16.4	51.8	24.3	18.3	53.4	15.6	14.6	55.4	19.9	16.6	56.9	
	700	1.5	3	18.4	16.4	52.7	21.5	18	54.8	15.6	14.9	55.8	18.6	16.7	57.8	12.2	12.2	58.4	14.8	14.8	60.2
				25.3	19.8	48.7	30.3	21.9	50.4	21	18	52.2	25.7	20	53.9	16.8	16.1	55.8	21.2	18.2	57.3
800	5.8	6	19.4	17.9	53.4	22.5	19.7	55.5	15.5	15.5	55.7	19.6	18.2	60.6	13	13	58.9	15.7	15.7	60.8	
			27.1	22.1	49.3	32.3	24.3	51.1	22.6	20.1	52.7	27.5	22.4	54.5	18	17.8	56.2	22.8	20.4	57.8	



# Model BDAH-02 Heating Data

	CFM	P.D. (Ft. H2O)	GPM	105°F Entering Water		110°F Entering Water		115°F Entering Water	
				70°F Entering Air		70°F Entering Air		70°F Entering Air	
				Total MB/H	Exit H2O°F	Total MB/H	Exit H2O°F	Total MB/H	Exit H2O°F
Heating Capacities based upon 0% Glycol	600	1.4	3	18.4	92.6	21	95.8	23.7	99
		5.1	6	20.6	98.1	23.6	102	26.6	106
	700	1.4	3	20.1	91.5	23	94.5	25.9	97.5
		5.1	6	23.1	97.2	26.5	101	29.8	104.9
	800	1.4	3	21.5	90.5	24.7	93.4	27.8	96.2
		5.1	6	25.4	96.4	29.1	100.2	32.8	103.9
950	1.4	3	23.3	89	26.7	92	30.1	94.5	
	5.1	6	28.3	95.5	32.5	99	36.6	102.7	
Heating Capacities based upon 10% Glycol	600	1.5	3	17.6	93	20.2	96.2	22.9	99.4
		5.4	6	20.3	98.1	23.3	102.1	26.2	106.1
	700	1.5	3	19.1	92	22	95	24.9	98.1
		5.4	6	22.7	97.3	26	101.2	29.4	105
	800	1.5	3	20.4	91.1	23.5	94	26.6	96.9
		5.4	6	24.9	96.6	28.5	100.3	32.1	104.1
950	1.5	3	22	90	25.3	92.8	28.7	95.5	
	5.4	6	27.7	95.6	31.7	99.2	35.8	102.8	
Heating Capacities based upon 20% Glycol	600	1.5	3	16.7	93.5	19.2	96.8	21.8	100
		5.7	6	19.9	98.2	22.8	102.2	25.8	106.1
	700	1.5	3	18	92.6	20.7	95.7	23.5	98.8
		5.7	6	22.1	97.4	25.4	101.3	28.7	105.1
	800	1.5	3	19.1	91.8	22	94.8	25	97.8
		5.7	6	24.1	96.7	27.7	100.5	31.3	104.2
950	1.5	3	20.4	90.9	23.6	93.7	26.8	96.5	
	5.7	6	26.6	95.9	30.6	99.5	34.7	102.8	

## Electric Heat Strip Information

PART#	DESCRIPTION
AH5KWHEAT	5KW ELECTRIC STRIP HEAT

## Electric Heat Strip Capacities

KW		BTU/H		TOTAL AMPS	
240V	208V	240V	208V	240V	208V
5KW	3.76KW	17050 BTU/H	12822 BTU/H	20.8 AMPS	18.1 AMPS

**NOTE:** The above listed heat strip part numbers and heat strip capacities data is only for the HSS® Air Handlers. These are specially designed for the electrical heat strip units for B&D Mfg., Inc. The electrical heat strip units are factory installed if ordered with electrical heat strip and can be field installed also if ordered without electrical heat strip.

# Model BDAH-03 Cooling Data

CFM	P.D. (ft. H2O)	GPM	40°F Entering Water						45°F Entering Water						50°F Entering Water						
			75°F DB/63°F WB Entering Air			80°F DB/67°F WB Entering Air			75°F DB/63°F WB Entering Air			80°F DB/67°F WB Entering Air			75°F DB/63°F WB Entering Air			80°F DB/67°F WB Entering Air			
			Total MB/H	Sens. MB/H	Exit H2O°F	Total MB/H	Sens. MB/H	Exit H2O°F	Total MB/H	Sens. MB/H	Exit H2O°F	Total MB/H	Sens. MB/H	Exit H2O°F	Total MB/H	Sens. MB/H	Exit H2O°F	Total MB/H	Sens. MB/H	Exit H2O°F	
1000	2.4	4	30.4	24.6	55.1	35.9	26.6	57.9	25.4	22	57.7	30.7	24.5	60.3	20.9	19.7	60.4	25.7	22.4	62.8	
			8.6	39.8	28.7	49.9	47.9	31.9	51.9	32.5	25.5	53.1	40.4	28.7	55.1	25.4	22.4	56.3	32.8	25.7	58.2
	2.4	4	31.5	25.7	55.7	37.2	28.1	58.5	26.5	23.3	58.2	31.9	25.9	60.9	21.9	20.8	60.9	26.8	23.7	63.4	
			8.6	41.7	30.6	50.4	50.1	33.9	52.5	34.2	27.2	53.5	42.3	30.6	55.5	26.8	24	56.7	34.5	27.5	58.6
	1200	2.4	4	32.5	27	56.2	38.3	29.5	59.1	27.5	24.5	58.7	32.9	27.3	61.4	21.1	21.1	60.8	27.9	24.9	63.9
				8.6	43.4	32.3	50.8	52.1	35.8	53	35.7	28.9	53.9	44	32.4	56	28.1	25.6	57	36	29.2
1350	2.4	4	33.8	28.6	56.8	39.6	31.4	58.8	28.8	26.1	59.3	34.3	29	60.4	22.2	22.2	61.1	29.1	26.6	64.6	
			8.6	45.7	34.8	51.4	54.7	38.4	53.6	37.7	31.3	54.4	46.2	34.9	56.6	30	27.8	57.5	38	31.5	59.5
1000	2.2	4	27.9	23.1	54.2	32.9	25.4	56.7	23.5	21.1	57	28.3	23	59.4	18.1	18.1	59.2	23.8	21.5	62.1	
			9.3	37.5	27.7	49.5	44.9	30.7	51.4	30.7	24.7	52.8	38	27.7	54.6	24.1	21.8	56.1	30.9	24.9	57.9
	2.2	4	28.9	24.5	54.7	34	26.8	57.3	24.5	22.3	57.4	29.3	24.8	59.9	18.9	19.9	59.6	24.8	22.7	62.6	
			9.3	39.2	29.4	50	46.9	32.6	51.9	32.2	26.4	53.2	39.7	29.5	55.1	25.4	23.4	56.5	32.4	26.6	58.2
	1200	2.2	4	29.8	25.7	55.1	34.9	28.1	57.7	25.4	23.4	57.9	30.2	26.1	60.3	19.6	19.6	60	25.7	23.8	63.1
				9.3	40.1	31.1	50.3	48.6	34.3	52.4	33.6	28	53.5	41.2	31.2	55.5	26.7	25	56.8	33.8	28.3
1350	2.2	4	30.8	27.2	55.7	36	29.8	58.4	26.4	24.8	58.5	31.3	27.8	61	20.5	20.5	60.5	26.9	25.2	63.6	
			9.3	42.7	33.4	50.9	50.9	36.8	42.9	35.3	30.2	54	43.2	33.7	55.9	28.3	26.9	57.3	35.5	30.6	59
1000	2	4	25.1	21.8	52.9	29.4	23.9	55.2	21.3	19.9	56	25.4	22.2	58.1	16.5	16.5	58.5	21.6	20.3	61.1	
			9.6	34.9	26.5	49	41.8	29.3	50.8	28.8	23.8	52.4	35.5	26.7	54.2	22.9	21.3	55.9	29.1	24.1	57.5
	2	4	25.9	23	53.4	30.3	25.2	55.6	22.1	20.9	56.4	26.2	23.4	58.5	17.2	17.2	58.9	22.4	21.3	61.6	
			9.6	36.4	28.2	49.4	43.5	31.1	51.2	30.2	25.4	52.8	37	28.4	54.5	24.1	22.8	56.2	30.4	25.8	57.9
	1200	2	4	26.7	24.1	53.8	31.1	26.4	56	21.1	21.1	55.9	27	24.5	58.9	17.7	17.7	59.1	21.4	21.4	61
				9.6	37.7	29.8	49.7	45	32.8	51.6	31.3	27	53.1	38.3	30.1	54.9	25.3	24.1	56.5	31.7	27.4
1350	2	4	27.7	25.5	54.3	32.1	28.1	56.6	21.9	21.9	56.3	28	25.9	59.3	18.4	18.4	59.5	22.3	22.3	61.5	
			9.6	39.6	32	50.3	47	35.1	52.1	33	29	53.5	40.2	32.3	55.4	26.9	26	56.8	33.3	29.5	58.6



# Model BDAH-03 Heating Data

	CFM	P.D. (Ft. H2O)	GPM	105°F Entering Water		110°F Entering Water		115°F Entering Water	
				70°F Entering Air		70°F Entering Air		70°F Entering Air	
				Total MB/H	Exit H2O°F	Total MB/H	Exit H2O°F	Total MB/H	Exit H2O°F
Heating Capacities based upon 0% Glycol	1000	2.1	4	29.2	90.3	33.4	93.1	37.7	96
		7.7	8	33.3	96.6	38.1	100.4	43	104.1
	1100	2.1	4	30.6	89.6	35.1	92.3	39.5	95
		7.7	8	35.6	96	40.8	99.7	47	103.4
	1200	2.1	4	31.9	88.9	36.6	91.5	41.2	94.2
		7.7	8	37.8	95.5	43.2	99.1	48.7	102.7
1350	2.1	4	33.6	88.1	38.5	90.5	43.4	93	
	7.7	8	40.7	95	46.5	98.3	52.4	101.7	
Heating Capacities based upon 10% Glycol	1000	2.3	4	27.9	90.8	32.1	93.7	36.4	96.5
		8.1	8	32.8	96.7	37.5	100.5	42.3	104.2
	1100	2.3	4	29.2	90.1	33.6	92.9	38.1	95.6
		8.1	8	35	96.1	40.1	99.8	45.2	103.5
	1200	2.3	4	30.4	89.6	35	92.2	39.6	94.8
		8.1	8	37	95.6	42.4	99.2	47.8	102.8
1350	2.3	4	31.8	75.8	36.7	91.4	41.6	93.8	
	8.1	8	39.8	94.9	45.5	98.5	51.3	101.9	
Heating Capacities based upon 20% Glycol	1000	2.4	4	26.2	91.5	30.2	94.4	34.3	97.3
		8.5	8	32	96.8	36.7	100.5	41.5	104.3
	1100	2.4	4	27.4	90.9	31.5	93.7	35.8	96.5
		8.5	8	34	96.2	39.1	99.9	44.2	103.6
	1200	2.4	4	28.3	90.4	32.7	93.1	37.1	95.9
		8.5	8	35.9	95.8	41.3	99.4	46.7	103
1350	2.4	4	29.6	89.7	34.1	92.3	38.8	95.8	
	8.5	8	38.4	95.6	44.2	98.6	51	102.1	

## Electric Heat Strip Information

PART#	DESCRIPTION
AH10KWHEAT	10KW ELECTRIC STRIP HEAT

## Electric Heat Strip Capacities

KW		BTU/H		TOTAL AMPS	
240V	208V	240V	208V	240V	208V
10KW	7.51KW	34100 BTU/H	25609 BTU/H	41.7 AMPS	36.1 AMPS

**NOTE:** The above listed heat strip part numbers and heat strip capacities data is only for the HSS® Air Handlers. These are specially designed for the electrical heat strip units for B&D Mfg., Inc. The electrical heat strip units are factory installed if ordered with electrical heat strip and can be field installed also if ordered without electrical heat strip.

# Model BDAH-04 Cooling Data

CFM	P.D. (ft. H2O)	GPM	40°F Entering Water						45°F Entering Water						50°F Entering Water					
			75°F DB/63°F WB Entering Air			80°F DB/67°F WB Entering Air			75°F DB/63°F WB Entering Air			80°F DB/67°F WB Entering Air			75°F DB/63°F WB Entering Air			80°F DB/67°F WB Entering Air		
			Total MB/H	Sens. MB/H	Exit H2O°F	Total MB/H	Sens. MB/H	Exit H2O°F	Total MB/H	Sens. MB/H	Exit H2O°F	Total MB/H	Sens. MB/H	Exit H2O°F	Total MB/H	Sens. MB/H	Exit H2O°F	Total MB/H	Sens. MB/H	Exit H2O°F
1400	2.4	6	44.5	34.8	54.8	52.7	38.2	57.5	37.2	31.6	57.4	45.1	35	60	30.5	28.4	60.1	37.7	32	62.5
			6.2	10	53.5	39	51	64.2	43.3	52.8	43.9	34.8	53.7	54.3	39.1	55.8	34.5	30.8	56.9	44.2
	2.4	6	45.8	36.3	55.2	54.1	39.7	58	38.5	33	57.8	46.4	36.6	60.4	31.6	29.7	60.5	38.9	33.5	62.9
			6.2	10	55.3	40.1	51	66.3	45.2	53.2	45.4	36.5	54.1	56.1	40.9	56.2	36	32.4	57.2	45.8
	2.4	6	47	37.6	55.6	55.4	41.2	58.4	39.6	34.3	58.2	47.5	38	60.8	32.7	30.9	60.9	40.1	34.9	63.3
			6.2	10	57	42.5	51.4	68.1	47	53.6	46.9	38.1	54.4	57.7	42.7	56.5	37.3	34	57.5	47.3
1600	2.4	6	48.5	39.6	56.1	57.1	43.3	59	41	36.1	58.7	49.2	40	61.4	31	31	57.1	41.6	36.6	63.9
			6.2	10	59.2	45	51.9	70.7	49.6	53.1	48.9	40.5	54.8	60	45.2	57	39.2	36.2	57.9	49.3
	2.2	6	41.1	33.2	53.9	48.4	36.4	56.4	34.6	30.3	56.7	41.6	33.6	59.1	26.1	26.1	58.8	35	30.8	61.8
			6.6	10	50.2	37.5	50.2	60.1	41.5	52.2	41.3	33.6	53.4	50.8	37.6	55.3	32.8	30	56.7	41.5
	2.2	6	42.2	34.6	54.3	49.7	37.9	56.8	35.7	31.7	57.1	42.7	35.1	59.5	26.9	26.9	59.1	36.1	32.2	62.2
			6.6	10	51.8	39.3	50.5	61.9	43.3	52.6	42.7	35.3	53.7	52.4	39.4	55.7	34.1	31.6	56.9	43
1750	2.2	6	43.2	35.9	54.6	50.8	39.3	57.2	36.6	32.9	57.4	43.8	36.4	59.8	27.7	27.7	59.4	37.1	33.5	62.6
			6.6	10	53.3	40.9	50.8	63.6	45	52.9	44	36.9	54	53.9	41.1	55.9	35.4	33.1	57.2	44.3
	2.2	6	44.5	37.8	55.2	52.3	41.2	57.7	38	34.5	57.9	45.2	38.3	60.4	28.6	28.6	59.7	38.5	35.2	63.1
			6.6	10	55.3	43.2	51.3	65.8	47.5	53.4	45.9	39.1	54.3	55.8	43.5	56.4	37.2	35.2	57.6	46.1
	2	6	37	31.4	52.7	43.4	34.3	54.9	31.4	28.8	55.8	37.4	31.9	57.9	23.7	23.7	58.2	31.8	29.3	60.9
			6.4	10	46.5	35.9	49.6	55.5	39.6	51.5	38.6	32.5	53	47.2	36.2	54.8	31.1	29.2	56.4	39
1500	2	6	37.9	32.7	53	44.4	35.7	55.3	32.3	30	56.1	38.4	33.2	58.2	24.4	24.4	58.4	32.7	30.6	61.3
			6.4	10	47.9	37.5	49.9	57.1	41.3	51.8	39.9	34.1	53.2	48.6	37.9	55	32.3	30.7	56.7	40.3
	2	6	38.8	33.9	53.4	45.4	37	55.6	33.1	31.1	56.4	39.3	34.5	58.5	25	25	58.6	33.6	31.7	61.6
			6.4	10	49.2	39.1	50.2	58.6	43	52.1	41.1	35.6	53.5	50	39.5	55.3	33.5	32.1	56.9	41.5
	2	6	39.9	35.5	53.6	46.5	38.8	56.6	32.5	31.5	56.2	40.5	36.1	59	25.9	25.9	58.8	31.2	31.2	60.7
			6.4	10	51	41.3	50.6	60.5	45.4	52.5	42.7	37.7	53.7	51.8	41.8	55.7	33.9	33.4	57	43.2





# Model BDAH-04 Heating Data

	CFM	P.D. (Ft. H2O)	GPM	105°F Entering Water		110°F Entering Water		115°F Entering Water	
				70°F Entering Air		70°F Entering Air		70°F Entering Air	
				Total MB/H	Exit H2O°F	Total MB/H	Exit H2O°F	Total MB/H	Exit H2O°F
Heating Capacities based upon 0% Glycol	1400	2.1	6	41.4	91.1	47.5	94	53.5	97
		5.5	10	46.1	95.7	52.7	99.3	59.4	103
	1500	2.1	6	43	90.6	49.2	93.4	55.5	96.3
		5.5	10	48.2	95.3	55.2	98.8	62.2	102.4
	1600	2.1	6	44.4	90.1	50.9	92.9	57.4	95.7
		5.5	10	50.3	94.9	57.6	98.4	64.9	101.9
1750	2.1	6	46.3	89.4	53.1	92.2	59.9	94.9	
	5.5	10	53.1	94.3	60.8	97.7	68.7	101.2	
Heating Capacities based upon 10% Glycol	1400	2.3	6	39.7	91.5	45.7	94.5	51.8	97.4
		5.8	10	45.1	95.8	51.7	99.5	58.3	103.1
	1500	2.3	6	41.1	91.1	47.3	94	53.6	96.8
		5.8	10	47.2	95.4	54.1	99	61	102.6
	1600	2.3	6	42.4	90.6	48.8	93.5	55.3	96.2
		5.8	10	49.1	95	56.3	98.6	63.5	102.1
	1750	2.3	6	44	90.1	50.7	92.8	57.5	95.5
		5.8	10	51.7	94.5	59.4	97.9	66.9	101.4
Heating Capacities based upon 20% Glycol	1400	2.4	6	37.3	92.2	43	95.2	48.8	98.2
		6.1	10	43.7	96	50.2	99.7	56.8	103.3
	1500	2.4	6	38.5	91.8	44.4	94.7	50.4	97.7
		6.1	10	45.5	95.6	52.4	99.2	59.3	102.8
	1600	2.4	6	39.6	91.4	45.7	94.3	51.9	97.2
		6.1	10	47.3	95.3	54.4	98.8	61.6	102.3
	1750	2.4	6	41	90.9	47.4	93.7	53.8	96.5
		6.1	10	49.6	94.8	57.1	98.2	64.8	101.7

## Electric Heat Strip Information

PART#	DESCRIPTION
AH10KWHEAT	10KW ELECTRIC STRIP HEAT
AH15KWHEAT	15KW ELECTRIC STRIP HEAT

## Electric Heat Strip Capacities

KW		BTU/H		TOTAL AMPS	
240V	208V	240V	208V	240V	208V
10KW	7.51KW	34100 BTU/H	25609 BTU/H	41.7 AMPS	36.1 AMPS
15KW	11.3KW	51150 BTU/H	38533 BTU/H	62.5 AMPS	54.3 AMPS

**NOTE:** The above listed heat strip part numbers and heat strip capacities data is only for the HSS® Air Handlers. These are specially designed for the electrical heat strip units for B&D Mfg., Inc. The electrical heat strip units are factory installed if ordered with electrical heat strip and can be field installed also if ordered without electrical heat strip.

# Model BDAH-05 Cooling Data

CFM	P.D. (Ft. H2O)	GPM	40°F Entering Water						45°F Entering Water						50°F Entering Water					
			75°F DB/63°F WB Entering Air			80°F DB/67°F WB Entering Air			75°F DB/63°F WB Entering Air			80°F DB/67°F WB Entering Air			75°F DB/63°F WB Entering Air			80°F DB/67°F WB Entering Air		
			Total MB/H	Sens. MB/H	Exit H2O°F	Total MB/H	Sens. MB/H	Exit H2O°F	Total MB/H	Sens. MB/H	Exit H2O°F	Total MB/H	Sens. MB/H	Exit H2O°F	Total MB/H	Sens. MB/H	Exit H2O°F	Total MB/H	Sens. MB/H	Exit H2O°F
1800	2.3	7	54.2	42.9	55.4	64.1	47.1	58.2	45.5	39.1	58	54.9	43.3	60.7	37.4	35.1	60.7	46	39.6	63.1
			66.7	49	51.1	79.9	54.2	53.3	54.6	43.7	54.1	67.6	49	56.2	43.1	38.7	57.2	55.1	44	59.2
	6.4	12	66.7	49	51.1	79.9	54.2	53.3	54.6	43.7	54.1	67.6	49	56.2	43.1	38.7	57.2	55.1	44	59.2
			66.7	49	51.1	79.9	54.2	53.3	54.6	43.7	54.1	67.6	49	56.2	43.1	38.7	57.2	55.1	44	59.2
	2.3	7	55.3	44.2	55.7	65.3	48.5	58.6	46.5	40.3	58.3	56	44.7	61	38.4	36.3	61	47.1	40.9	63.4
			68.3	50.6	51.3	81.8	56	53.6	56.1	45.3	54.3	69.2	50.8	56.5	44.4	40.3	57.4	56.6	45.7	59.4
6.4	12	68.3	50.6	51.3	81.8	56	53.6	56.1	45.3	54.3	69.2	50.8	56.5	44.4	40.3	57.4	56.6	45.7	59.4	
		68.3	50.6	51.3	81.8	56	53.6	56.1	45.3	54.3	69.2	50.8	56.5	44.4	40.3	57.4	56.6	45.7	59.4	
2.3	7	56.3	45.5	56	66.5	49.9	58.9	47.6	41.5	58.6	57.1	46	61.3	35.9	35.9	60.2	48.2	42.2	63.7	
		69.9	52.3	51.6	83.6	57.8	53.9	57.5	46.9	54.6	70.8	52.4	56.8	45.7	41.7	57.6	58	47.3	59.6	
6.4	12	69.9	52.3	51.6	83.6	57.8	53.9	57.5	46.9	54.6	70.8	52.4	56.8	45.7	41.7	57.6	58	47.3	59.6	
		69.9	52.3	51.6	83.6	57.8	53.9	57.5	46.9	54.6	70.8	52.4	56.8	45.7	41.7	57.6	58	47.3	59.6	
2.3	7	57.8	47.3	56.5	68	51.7	59.4	49.1	43.3	58.9	58.6	47.8	61.7	37	37	60.6	49.6	43.9	64.2	
		72	54.5	51.8	86.1	59.8	54.3	59.4	49	54.9	73	54.9	57.1	47.5	43.9	57.9	59.9	49.6	59.9	
6.4	12	72	54.5	51.8	86.1	59.8	54.3	59.4	49	54.9	73	54.9	57.1	47.5	43.9	57.9	59.9	49.6	59.9	
		72	54.5	51.8	86.1	59.8	54.3	59.4	49	54.9	73	54.9	57.1	47.5	43.9	57.9	59.9	49.6	59.9	
2.2	7	49.8	40.9	54.5	58.7	44.8	57	42.1	37.4	57.2	50.5	41.4	59.6	31.8	31.8	59.2	42.6	38.1	62.4	
		62.4	47	50.6	74.5	51.9	52.6	51.3	42.2	53.7	63.1	47.1	55.7	40.8	37.7	56.9	51.6	42.6	58.7	
6.8	12	62.4	47	50.6	74.5	51.9	52.6	51.3	42.2	53.7	63.1	47.1	55.7	40.8	37.7	56.9	51.6	42.6	58.7	
		62.4	47	50.6	74.5	51.9	52.6	51.3	42.2	53.7	63.1	47.1	55.7	40.8	37.7	56.9	51.6	42.6	58.7	
2.2	7	50.8	42.2	54.7	59.7	46.2	57.3	43	38.6	57.5	51.5	42.8	59.9	32.6	32.6	59.5	43.6	39.3	62.7	
		63.8	48.6	50.8	76.2	53.6	52.9	52.6	43.8	53.9	64.6	48.8	55.9	42.1	39.1	57.1	53	44.2	59	
6.8	12	63.8	48.6	50.8	76.2	53.6	52.9	52.6	43.8	53.9	64.6	48.8	55.9	42.1	39.1	57.1	53	44.2	59	
		63.8	48.6	50.8	76.2	53.6	52.9	52.6	43.8	53.9	64.6	48.8	55.9	42.1	39.1	57.1	53	44.2	59	
2.2	7	51.7	43.4	55	60.7	47.5	57.6	44	39.7	57.8	52.4	44	60.2	33.3	33.3	59.7	44.5	40.4	62.9	
		65.2	50.2	51	77.8	55.3	53.2	53.9	45.3	54.1	65.9	50.4	56.2	43.3	40.5	57.3	54.2	45.8	59.2	
6.8	12	65.2	50.2	51	77.8	55.3	53.2	53.9	45.3	54.1	65.9	50.4	56.2	43.3	40.5	57.3	54.2	45.8	59.2	
		65.2	50.2	51	77.8	55.3	53.2	53.9	45.3	54.1	65.9	50.4	56.2	43.3	40.5	57.3	54.2	45.8	59.2	
2.2	7	53	45.1	55.4	62	49.2	58	45.2	41.3	58.1	53.7	45.8	60.5	34.2	34.2	59.9	45.8	42	63.3	
		67.1	52.3	51.4	79.9	57.6	53.6	55.6	47.4	54.4	67.8	52.6	56.5	45	42.6	57.6	56	48	59.5	
6.8	12	67.1	52.3	51.4	79.9	57.6	53.6	55.6	47.4	54.4	67.8	52.6	56.5	45	42.6	57.6	56	48	59.5	
		67.1	52.3	51.4	79.9	57.6	53.6	55.6	47.4	54.4	67.8	52.6	56.5	45	42.6	57.6	56	48	59.5	
2	7	44.8	38.7	53.2	52.5	42.2	55.5	38.1	35.4	56.2	45.4	39.3	58.4	28.9	28.9	58.5	38.6	36.1	61.4	
		57.6	44.9	49.9	68.7	49.5	51.8	47.9	40.7	53.2	58.5	45.3	55.1	38.6	36.6	56.6	48.4	41.3	58.3	
6.6	12	57.6	44.9	49.9	68.7	49.5	51.8	47.9	40.7	53.2	58.5	45.3	55.1	38.6	36.6	56.6	48.4	41.3	58.3	
		57.6	44.9	49.9	68.7	49.5	51.8	47.9	40.7	53.2	58.5	45.3	55.1	38.6	36.6	56.6	48.4	41.3	58.3	
2	7	45.7	39.8	53.5	53.4	43.5	55.7	38.9	36.5	56.5	46.2	40.5	58.6	29.5	29.5	58.7	39.5	37.2	61.6	
		58.9	46.5	50.1	70.2	51.1	52.1	49.1	42.2	53.4	59.8	46.9	55.3	39.8	38	56.8	49.6	42.8	58.5	
6.6	12	58.9	46.5	50.1	70.2	51.1	52.1	49.1	42.2	53.4	59.8	46.9	55.3	39.8	38	56.8	49.6	42.8	58.5	
		58.9	46.5	50.1	70.2	51.1	52.1	49.1	42.2	53.4	59.8	46.9	55.3	39.8	38	56.8	49.6	42.8	58.5	
2	7	46.4	40.9	53.7	54.2	44.7	56	39.7	37.5	56.7	47	41.6	58.9	30.1	30.1	58.9	36.3	36.3	60.7	
		60.1	47.9	50.3	71.6	52.7	52.3	50.2	43.6	53.6	61	48.4	55.5	40.9	39.3	57	50.7	44.3	58.7	
6.6	12	60.1	47.9	50.3	71.6	52.7	52.3	50.2	43.6	53.6	61	48.4	55.5	40.9	39.3	57	50.7	44.3	58.7	
		60.1	47.9	50.3	71.6	52.7	52.3	50.2	43.6	53.6	61	48.4	55.5	40.9	39.3	57	50.7	44.3	58.7	
2	7	47.5	42.4	53.9	55.3	56.4	56.3	36.6	36.6	55.8	48.1	43.2	59.2	30.8	30.8	58.9	37.2	37.2	61	
		61.8	51	50.6	73.4	55	52.6	51.7	45.6	53.9	68	50.6	55.8	42.4	41.1	57.3	52.3	46.4	59	
6.6	12	61.8	51	50.6	73.4	55	52.6	51.7	45.6	53.9	68	50.6	55.8	42.4	41.1	57.3	52.3	46.4	59	
		61.8	51	50.6	73.4	55	52.6	51.7	45.6	53.9	68	50.6	55.8	42.4	41.1	57.3	52.3	46.4	59	



# Model BDAH-05 Heating Data

	CFM	P.D. (Ft. H2O)	GPM	105°F Entering Water		110°F Entering Water		115°F Entering Water	
				70°F Entering Air		70°F Entering Air		70°F Entering Air	
				Total MB/H	Exit H2O°F	Total MB/H	Exit H2O°F	Total MB/H	Exit H2O°F
Heating Capacities based upon 0% Glycol	1800	2.1	7	51	90.3	58.5	93.1	66	95.9
		5.7	12	57.8	95.3	66.1	98.9	74.5	102.4
	1900	2.1	7	52.4	89.9	60.1	92.7	67.8	95.4
		5.7	12	59.8	94.9	68.5	98.5	77.2	102
	2000	2.1	7	53.8	89.5	61.6	92.2	69.5	94.9
		5.7	12	61.8	94.6	70.7	98.1	79.7	101.6
2150	2.1	7	55.6	89	63.6	91.6	71.8	94.2	
	5.7	12	64.4	94.2	73.9	97.6	82.7	101	
Heating Capacities based upon 10% Glycol	1800	2.2	7	48.7	90.8	56.1	93.7	63.6	96.5
		6	12	56.5	95.4	64.8	99	73.1	102.6
	1900	2.2	7	50	90.5	57.5	93.3	65.2	96
		6	12	58.5	95.1	67	98.6	75.6	102.2
	2000	2.2	7	51.1	90.1	58.9	92.9	66.8	95.6
		6	12	60.3	94.8	69.1	98.3	78	101.8
2150	2.2	7	52.7	89.7	60.7	92.3	68.9	95	
	6	12	62.8	94.5	72.1	97.8	81.3	101.2	
Heating Capacities based upon 20% Glycol	1800	2.3	7	45.6	91.6	52.6	94.5	59.7	97.4
		6.3	12	54.5	95.6	62.8	99.2	71.1	102.8
	1900	2.3	7	46.7	91.2	53.9	94.1	61.2	97
		6.3	12	56.3	95.3	64.8	98.9	73.4	102.4
	2000	2.3	7	47.7	91	55	93.8	62.5	96.6
		6.3	12	58	95	66.7	98.5	75.6	102
2150	2.3	7	49.1	90.6	56.6	93.4	64.2	96.1	
	6.3	12	59.9	94.7	69.4	98.1	78.6	101.5	

## Electric Heat Strip Information

PART#	DESCRIPTION
AH10KWHEAT	10KW ELECTRIC STRIP HEAT
AH15KWHEAT	15KW ELECTRIC STRIP HEAT

## Electric Heat Strip Capacities

KW		BTU/H		TOTAL AMPS	
240V	208V	240V	208V	240V	208V
10KW	7.51KW	34100 BTU/H	25609 BTU/H	41.7 AMPS	36.1 AMPS
15KW	11.3KW	51150 BTU/H	38533 BTU/H	62.5 AMPS	54.3 AMPS

**NOTE:** The above listed heat strip part numbers and heat strip capacities data is only for the HSS® Air Handlers. These are specially designed for the electrical heat strip units for B&D Mfg., Inc. The electrical heat strip units are factory installed if ordered with electrical heat strip and can be field installed also if ordered without electrical heat strip.

## Model BDAH-01 Boiler Heating Data

Heating Capacities based upon 0% Glycol								
CFM	P.D. (Ft. H <sub>2</sub> O)	GPM	130°F Entering Water		155°F Entering Water		180°F Entering Water	
			70°F Entering Air		70°F Entering Air		70°F Entering Air	
			Total MB/H	Exit H <sub>2</sub> O°F	Total MB/H	Exit H <sub>2</sub> O°F	Total MB/H	Exit H <sub>2</sub> O°F
300	2.2	2	16.5	113.3	23.5	131	30.6	148.5
	4.7	3	17.5	119.2	24.9	138.1	32.3	157.9
	8	4	17.9	120.9	25.5	142	33.1	163
350	2.2	2	18.2	111.6	26	128.5	33.8	160.8
	4.7	3	19.5	116.8	27.9	136	36.2	128.5
	8	4	20.2	119.7	28.8	140.3	37.4	136
400	2.2	2	19.7	110.1	28.1	126.3	36.6	142.3
	4.7	3	21.4	115.5	30.5	134.2	39.7	152.8
	8	4	22.3	118.7	31.8	138.8	41.3	158.8
500	2.2	2	22.1	107.6	31.6	122.7	41.3	137.5
	4.7	3	24.6	113.4	35.1	131.1	45.7	148.6
	8	4	26	116.9	37	136.1	48.1	155.3

## Model BDAH-02 Boiler Heating Data

Heating Capacities based upon 0% Glycol								
CFM	P.D. (Ft. H <sub>2</sub> O)	GPM	130°F Entering Water		155°F Entering Water		180°F Entering Water	
			70°F Entering Air		70°F Entering Air		70°F Entering Air	
			Total MB/H	Exit H <sub>2</sub> O°F	Total MB/H	Exit H <sub>2</sub> O°F	Total MB/H	Exit H <sub>2</sub> O°F
600	1	2	29.2	100.4	41.7	112.4	54.2	124.2
	2.1	3	33	107.7	47.1	122.9	61.2	138
	3.6	4	35	112.3	50	129.6	64.7	146.8
700	1	2	31.4	98.1	44.8	109.2	58.3	120
	2.1	3	36.3	105.5	51.8	119.8	67.3	133.8
	3.6	4	38.9	110.3	55.4	126.7	72.1	142.9
800	1	2	33.2	96.3	47.4	106.6	61.7	116.5
	2.1	3	39	103.6	55.7	117.1	72.5	130.3
	3.6	4	42.3	108.5	60.4	124.2	78.5	139.6
950	1	2	35.4	94.1	50.6	103.3	65.8	112.3
	2.1	3	42.5	101.3	60.7	113.7	79	125.8
	3.6	4	46.8	106.3	66.8	120.9	86.9	135.3

## Model BDAH-03 Boiler Heating Data

Heating Capacities based upon 0% Glycol								
CFM	P.D. (Ft. H2O)	GPM	130°F Entering Water		155°F Entering Water		180°F Entering Water	
			70°F Entering Air		70°F Entering Air		70°F Entering Air	
			Total MB/H	Exit H2O°F	Total MB/H	Exit H2O°F	Total MB/H	Exit H2O°F
1000	0.8	2	38	91.4	54.2	99.6	70.4	107.5
	4.1	5	54.4	107.9	77.5	123.3	100.8	138.5
	9.8	8	58.9	115.1	83.8	133.6	108.9	152
1100	0.8	2	39.2	90.2	55.9	97.8	72.7	105.2
	4.1	5	57.6	106.6	82.2	121.4	106.9	136
	9.9	8	63.2	114	90	132	116.9	149.9
1200	0.8	2	40.3	89.1	57.5	96.3	74.6	103.1
	4.1	5	60.6	105.4	86.4	119.7	112.4	133.7
	9.9	8	67.2	112.9	95.8	130.6	124.5	148
1350	0.8	2	41.6	87.8	59.4	94.3	77.1	100.6
	4.1	5	64.5	103.8	92.1	117.4	119.8	130.7
	9.9	8	72.7	111.6	103.6	128.6	134.7	145.4

## Model BDAH-04 Boiler Heating Data

Heating Capacities based upon 0% Glycol								
CFM	P.D. (Ft. H2O)	GPM	130°F Entering Water		155°F Entering Water		180°F Entering Water	
			70°F Entering Air		70°F Entering Air		70°F Entering Air	
			Total MB/H	Exit H2O°F	Total MB/H	Exit H2O°F	Total MB/H	Exit H2O°F
1400	2.5	5	72.1	100.8	102.8	113	133.8	124.9
	4.7	7	78.9	107.1	112.6	122.2	146.4	137
	7.4	9	82.6	111.4	117.7	128.3	152.9	145.1
1500	2.5	5	74.6	99.7	106.5	111.5	138.6	122.9
	4.7	7	82.4	106.1	117.6	120.7	152.9	135.1
	7.4	9	86.7	110.5	123.5	127	160.6	143.3
1600	2.5	5	77	98.8	109.9	110.1	143	121.1
	4.7	7	85.7	105.2	122.2	119.3	159	133.3
	7.4	9	90.5	109.6	129	125.7	167.8	141.7
1750	2.5	5	80.1	97.5	114.4	118.7	148.9	118.7
	4.7	7	90.1	103.9	128.6	130.8	167.3	130.8
	7.4	9	95.9	108.4	136.7	139.4	177.8	139.4

# Model BDAH-05 Boiler Heating Data

Heating Capacities based upon 0% Glycol								
CFM	P.D. (Ft. H2O)	GPM	130°F Entering Water		155°F Entering Water		180°F Entering Water	
			70°F Entering Air		70°F Entering Air		70°F Entering Air	
			Total MB/H	Exit H2O°F	Total MB/H	Exit H2O°F	Total MB/H	Exit H2O°F
1800	2.18	5	82.9	96.3	118.3	106.6	153.9	116.6
	4.04	7	93.5	102.9	133.4	116.1	173.5	129
	6.4	9	99.6	107.5	142	122.8	184.6	137.8
1900	2.18	5	84.8	95.6	121	105.5	157.4	115.2
	4.04	7	96.3	102.1	137.3	114.9	178.6	127.5
	6.41	9	103	106.8	146.8	121.7	190.9	136.4
2000	2.18	5	86.6	94.9	123.5	104.5	160.6	114
	4.04	7	98.8	101.3	141	113.8	183.5	126
	6.41	9	106.2	106.1	151.4	120.6	196.9	135
2150	2.18	5	89	93.9	126.9	103.1	165	112
	4.04	7	102.4	100.3	146.1	112.4	190.1	124.1
	6.42	9	110.6	105	157.8	119.2	205.3	133.1



“B & D Mfg. Inc.’s mission is to bring geothermal innovation to the forefront of green energy. Our goal is to utilize non-pressurized products, while meeting all geothermal product needs. We strive to always have the products our distributors need in stock. As one of the leaders in geothermal, B & D plans to grow with the industry and continue to push the industry with creative ideas, quality products, and great distributor service.”

**B & D MFG., INC.**

**901 9TH STREET**

**SCRANTON, IA 51462**

**Ph: 1-866-646-6724 or 712-652-3424**

**Fax: 1-800-952-7101 or 712-652-3388**



**[WWW.BDMFGINC.COM](http://WWW.BDMFGINC.COM)**